

PROVIX.NET
Now I CAN SEE!



Camera Systems, Lighting & Alarms

SAFETY SYSTEMS FOR COMMERCIAL VEHICLES

sales@provix.net • www.PROVIX.net • (888)434-0253



PROVIX IN YOUR REGION?

PROVIX.NET
Now I CAN SEE!

Camera & Video Systems for municipal vehicles and equipment, sewer inspection and process monitoring



Camera Systems, Lighting & Alarms

SYSTEMS FOR MUNICIPAL EQUIPMENT

PROVIX is Vision Enhancement

PROVIX enhances vision through the deployment of technologically advanced camera systems. Camera systems that have many variations available: Heated, Waterproof, 360° view, on screen distance markers, lens shutter, infrared, night vision etc.

We supply a variety of safety and video systems such as :

- Rear-View Camera systems
- Self-adjusting Reversing alarms
- Roadwatch- Road temperature Monitoring system
- Warning Lights/ Light bars
- Remote Controlled Spot Lights
- Portable/ battery operated lights
- Confined Space Communication System
- Sewer Inspection Camera System
- Incident Recording Systems
- Fleet management/ GPS Tracking
- Dash Cams
- Camera Wash and Air Cleaning Systems
- Traffic Advisors
- SWS Lights
- Go Lights
- K&H lights
- Flood/ Spot Work Lights
- LED Strobes
- Proximity Detection/ Radar Sensor Systems



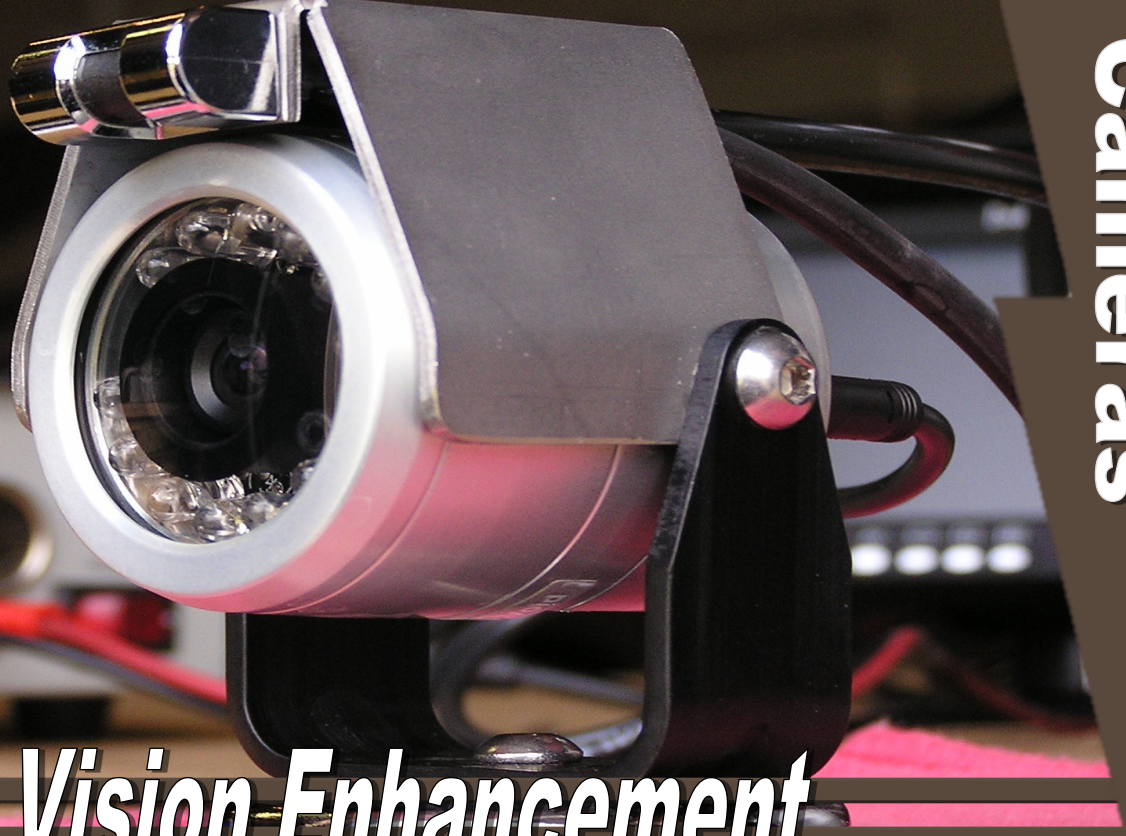

Provox is Vision Enhancement

TYPES OF CAMERAS

- HEATED
- SHUTTER
- THERMAL IMAGING
- PROCESS MONITORING
- SEWER INSPECTION
- 360° PANORAMIC
- PAN / TILT / ZOOM CAMERAS
- CAMERAS WITH INTEGRATED IR'S AND WHITE LIGHT
- TRIGGERED EVENT MONITORING

TYPES OF EQUIPMENT

- SNOWPLOWS
- WASTE TRUCKS
- SKID STEER / DOZERS
- FIRE TRUCKS
- CRANES
- FORKLIFTS
- SHUTTLE BUGGY
- COMPACTOR
- EXCAVATOR
- STREET SWEEPER

PROVIX.NET
Now I CAN SEE!



HEATED WATERPROOF CAMERA WITH SHUTTER (IP69)



Snowplow Camera System

CALL TOLL FREE: 1-888-434-0253 — CONTACT: SALES@PROVIX.NET — VISIT: WWW.PROVIX.NET

WASTE MANAGEMENT CAMERA SYSTEM WITH RECORDING

**360°
FIELD OF VIEW**

PROVIX Waste Management System with recording includes automatic reverse activated or "switch on when required" heated rear view shutter cameras, and forward facing bullet style cameras with 360 degree field of view. Operators can see everything behind and in front of their vehicle, regardless of seating position. The 7" LCD TFT monitors include DVRs that record all four cameras all the time, and with 32 GB SD cards, an entire shift can be recorded. Cameras are waterproof and the vehicle mounted DVR monitors offer auto brightness control as well as intuitive menus and high resolution viewing. Monitors will display cameras based on the direction of travel, or all four cameras simultaneously.



PROVIX.NET
Now I CAN SEE!

Street Sweeper Camera System

Shutter keeps lens clean when not in use



Monitor Specifications:

LCD size: 7.0 inch (178 mm)

Brightness: 400cd/M²

Contrast Ratio: 500:1

Dimensions: 185 x 124 x 48 mm

Dimensions: 7 x 5 x 1 inch

Viewing Angle: Up/45°, Dwn/65°, R/65°, L/65°

Power Consumption: 12W (12V/1A)

Temperature Range: -25° C to 70° C

24/12 Volt Power Regulator Built-In

Supports 3 Camera Inputs

Shutter Camera Specifications:

View Angle: 120°

Image Sensor: OV7949 1/3" Color

Resolution: 420 Lines

Shutter (Lens cover): 1/60s~12uSec

Temperature Range: -25° C to 70° C

Illumination: 0.1 Lux F:2.0

Power (LED on): 12 VDC, 450 mA

Built-in Microphone

Water-tight Cables 20 meter (66 ft)

12 "IR" Infrared lamps

CALL TOLL FREE: 1-888-434-0253 — CONTACT: SALES@PROVIX.NET — VISIT: WWW.PROVIX.NET

Excavator Camera System



7" Digital Screen TFT LCD
Color Quad Monitor with
Removable Sun Visor



Heavy Duty
Industrial
Boom/Stick
Camera



Heated Rear view
Counterweight Camera with
steel camera guard

- System is designed to eliminate blind spots, increase safety and improve productivity for the excavator operator.
- Reversing camera to enhance operators view of swing area
- Boom camera to view the operation of the excavator attachment; boring, ripping, crushing, cutting, lifting, etc.

Optional: Vibration mount

Skid Steer Camera System



Instant improvements in:

- Enhanced Vision
- Mobile Safety
- Increased Productivity



7" Digital Screen
TFT LCD Color
Monitor with
Removable Sun
Visor

Heated Rear view
Counterweight
Camera with steel
camera guard



Aerial View Camera System

4 Cameras, 1 Image, 0 Blind Spots

Operator has birds eye view of equipment and surroundings

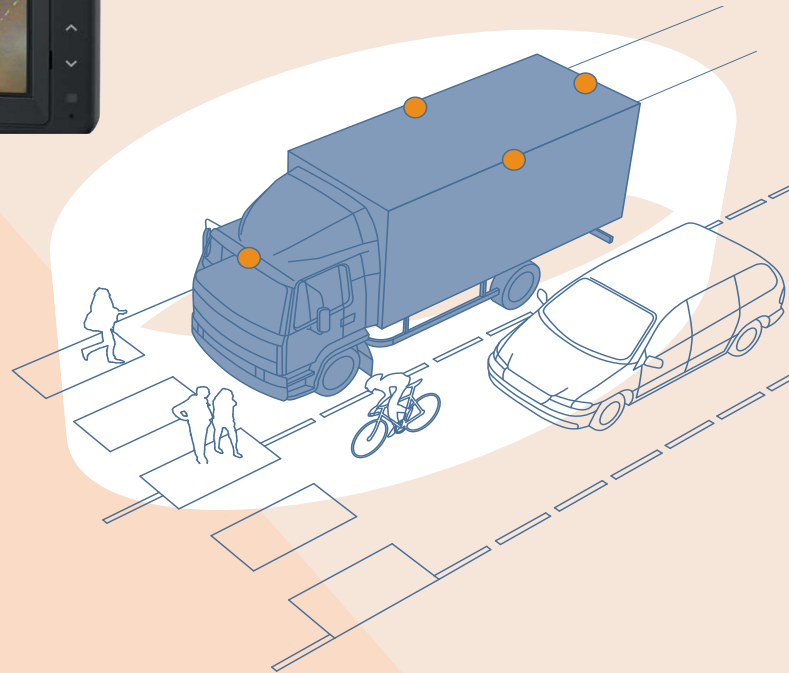
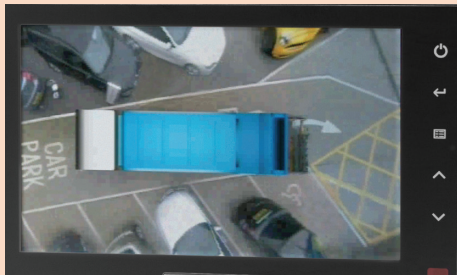

Features & Benefits

- Applicable for ALL mobile equipment
- Four 180 Camera Lenses cover the entire perimeter and surroundings, including all blind spots
- Real-time video output
- Birds Eye View of your equipment and surroundings
- Comprehensive "all-round" view of vehicle in a single image

360° Aerial View provides the operator with full situational awareness of anyone or anything that is behind, in front, or on either side of the vehicle

Four cameras provide images from each side of the vehicle- those images are then then stitched together much like taking a panoramic picture.

The operator of the vehicle has a Split Screen view that displays both the 360° Aerial view as well as the video display from camera facing in the direction of travel.

No operator intervention is required- Camera views are triggered automatically based on the direction of travel.

360° Camera lens totally eliminates all blind spots

Split Screen Viewing eliminates Screen clutter and offers rapid identification of obstacles or people.

360° camera system is suitable for any type of equipment where the operator has reduced or restricted line of sight or "blindspots"

Heavy Equipment Camera System



WITH DISTANCE GRID LINES



7" TFT- LCD color monitor with digital screen
Product: 7" TFT- LCD color monitor digital screen
Audio output: 1W.
Loudspeaker: one 15x24mm round loudspeaker.
Power supply: Automobile storage battery (10-32V).
Power consumption: about 6W .
Outer dimension: 1946.6mm (W) x 128mm (H) x 39.3mm (T)
Dot pitch: 0.192 (H) x 0.1805 (V).
Resolution: 800x3 (RGB) x 480.
Contrast: 500:1.
Brightness: 400 cd/ m².
Viewing angle: U: 50° / D: 60°, R/L: 70° /70°
Operating temperature: -20°C—+70°C, RH90%.
Storage temperature: -30°C—+80°C, RH90%
15 G-force rated shock resistant for the monitor

Image Device: SHARP
TV System: PAL / NTSC
Effective Pixels: 512 x 582 pixels / 512 x 492 pixels
Sensing Area: 4.9mm x 3.7mm
Scanning System: 2:1Interlace
Sync. System: Internal
Resolution: 420TV lines
Horizontal Sync. Frequency: 15.625KHz / 15.734KHz
Vertical Sync. Frequency: 50Hz / 60Hz Minimum Illumination: 0
Lux/F1.2 with IR Microphone: Optional
Video Output: 1.0vp-p, 75Ohm
Gamma Consumption: 0.45
AGC: Auto
S/N Ratio: Better than 48dB
White Balance: Auto
Electronic Shutter: 1/60(NTSC) / 1/50(PAL) ~ 1/10,000 Seconds
BLC: Auto
Current Consumption: Max. 300mA
Power Supply: DC12V
Operating Temperature: -20°C~70°C , RH95% MAX
Storage Temperature: -40°C~80°C, RH95% MAX
Lens: f=3.6mm / 2.8mm F = 2.0
Lens Angle: 92/120



PROVIX.NET
NOW I CAN SEE!

Crane Camera System



- Vision Enhancement
- Increased Productivity
- Overhead Safety
- Less Material Damage



CALL TOLL FREE: 1-888-434-0253 — CONTACT: SALES@PROVIX.NET — VISIT: WWW.PROVIX.NET

Provix RoadWatch System

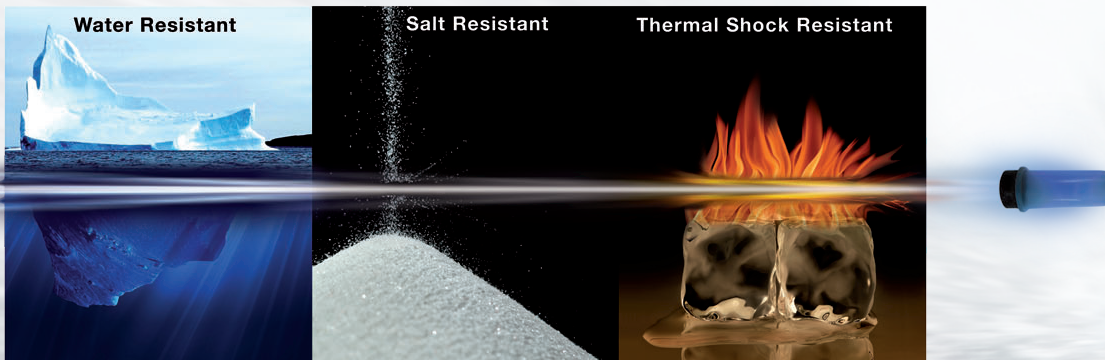

Road surface temperature sensors from RoadWatch Bullet use state-of-the-art infrared measuring, which assures accurate, real-time road surface temperature information critical to proper deployment of anti-icing and de-icing materials. With RoadWatch Bullet, the pavement temperature sensors create an alert of existing hazardous conditions for driver safety.

NEW SENSOR

Introducing RoadWatch Bullet™

- Unmatched Reliability
- Improved Performance
- Affordably Priced
- Backwards Capability
- Constant Feedback on Road Surface Conditions
- Easy to Install and Service
- Can Operate as Standalone or Integrated with Other Vehicle Controls



UNPRECEDENTED RELIABILITY

- ✓ Fully-sealed sensor
- ✓ Connector mating inside sleeve
- ✓ No screws or openings in sensor face
- ✓ Environmentally tested

IMPROVED PERFORMANCE

- ✓ Faster acclimation time
- ✓ Improved accuracy
- ✓ More durable, with low total lifetime cost

BACKWARDS COMPATIBILITY

Use with existing:

- ✓ Cables and connectors
- ✓ Displays
- ✓ RS-232 Convertors

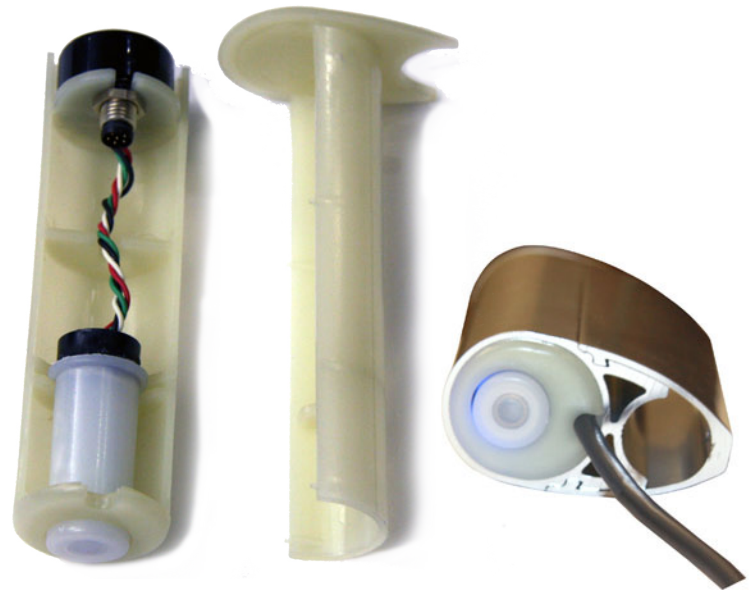

Technical Specifications

Environmental

- System Operating Range: -40 to +150 °F
- Thermal Shock: ISO 16750-4 (2010) Section 5.3.1.3
- Water Immersion: ISO 20653 Section 6 IPX7
- Salt Fog: ISO 16750-4 (2010) Section 5.5.2.1
- Storage Range: -40 to 75 °C or -40 to 167 °F
- Relative Humidity: 98% non-condensing
- Vibration: 4g, sensor & display
- Shock: 100g sensor element

Performance

- Road Accuracy: ± 2 °F (15 to 100 °F under ambient stable)
- Air Accuracy: ± 2 °F (-40 to 131 °F) while moving > 5 MPH
- Field Calibration: accuracy ± 1 °F (0 to 100 °F)
- Repeatability: ± 1 °F under stable ambient conditions
- Emissivity: factory calibrated at 0.96
- Field of View Angle: 5° typical
- Weight: 11oz sensor, 3oz display

Electrical

- Operating Voltage: 9-28Vdc
- Current Requirement: 0.1A
- Sensor Data Rate: 4 readings per second
- J1708 Data Format

Provix Roadwatch System

Accessories



**Magnetic Mount
for Pickups**

SFI-RW3291-00



**Suction Cup Mount
for Pickups**

replacement suction
cups are available

SFI-RW3275-00



**Large West Coast
Mirror Bracket**

SFI-RWA2771-25



**Sensor and
Housing**

**Sensor,
Cable, &
Mounting
Hardware**

SFI-RW849-1242-001





Gauge Cup
(display gauge not included)

SFI-RW9925

Gauge & Mounting Hardware
MSF8490260000
Service Part
SFI-
RW849-00930
01



Stainless Steel "C" Bracket

SFI-RWGB12

Sensor Flat Mount

SFI-RW014-0007-000

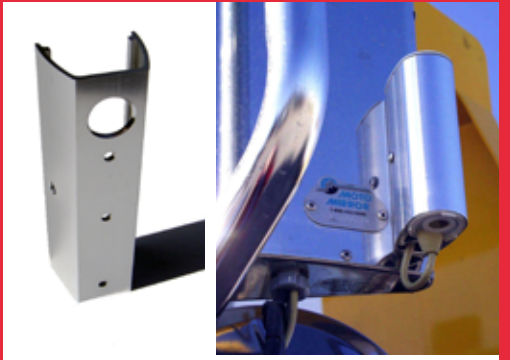

12V Quick Connect Power Cable SFI-RW3269



Field Calibration Unit SFI-RW849100000



12V Vehicle Power Cable SFI-RW2701559



Adapter Cables (Limited Supply)



RS232 Adapter Box SFI-RW8490099000



Extension Cables

SFI-RW4340104000
M8 Female to EDAC
Male
(to replace sensor)

1.5 Foot SFI-RW434-1100-015
4 Foot SFI-RW434-0100-002
12 Foot SFI-RW434-1100-000
16 Foot SFI-RW434-0100-001



NEW

TRACKER

VEHICLE TRACKING SYSTEM



Save money with better resource management

- Bluetooth connect for easy installation
- Records location, vehicle and road condition metrics
- Unique low cost 'Smart Device' approach
- Easy to read data presentation
- Can operate as standalone or integrated with other vehicle controls



RoadWatch® Tracker Includes:
Roadwatch® Tracker RS232 with Bluetooth Low-Energy (BLE) Module and Power Cable. Not included: RoadWatch Sensor Head, Extension Cable, Temperature Display or Smart Device

ROADWATCH PRODUCTS

	Part Number	Description	
ROADWATCH TRACKER	MSF849-1099-010	Roadwatch® Tracker RS232 with BLE kit <i>Includes:</i> <ul style="list-style-type: none"> • ECU • M12 power and plow signal cable 	
ROADWATCH SENSORS & ACCESSORIES	849-1262-002	Roadwatch® System Kit (Celsius)	
	849-1262-003	Roadwatch® System Kit (Fahrenheit)	
	849-0242-000	Roadwatch® Sensor only kit with 12" cable (Fahrenheit)	
	849-0242-001	Roadwatch® Sensor only kit with 12" cable (Celsius)	
	849-0260-000	Roadwatch® Display only kit	
	434-0114-000	M8 cable 'Y' splitter (Recommended)	

IMPROVE ROUTE EFFICIENCY

Vehicle tracking has never been easier

•Records location, vehicle, and road condition metrics

- AVL and GPS location in real-time*
- Vehicle MPH including stop and idle time
- Complete spreader info** plus plow up/down

•Unique low cost 'Smart Device' approach

- Works on most Android phones and tablets
- Requires only Roadwatch® Tracker RS232 with BLE kit for wireless interface
- No costly cellular data service required for WiFi based transfer mode
- Easy to install and portable

•Easy to read data presentation

- Custom icons used to identify vehicle types
- Graphically shows plow and spreader status
- Color coded road temps and treatment paths
- Stop sign icon showing stops and idles with hover-over time details
- Data compatible with free viewing tools such as ArcGIS® and Google Earth®

*3rd party cellular data service required

**Requires compatible spreader

Provix Inspection Camera System

20m, 30m, 40m Cable



- ◆ 1/3 inch Sony CCD camera, 120° wide view angle
- ◆ Stainless steel short camera head, IP 68 water proof level
- ◆ Sapphire glass lens cover, 12 white LEDs
- ◆ Diameter of camera: 23 mm, suitable for pipe dia. 25-200mm
- ◆ 20-40M fiberglass rod cable with stainless reel
- ◆ Cable reel rotatable in the case
- ◆ One touch record/still images button
- ◆ 7" TFT LCD monitor with DVR
- ◆ Rechargeable High capacity Li-battery (6600mA) for 8 hours continuous working
- ◆ Waterproof ABS suitcase with all parts included
- ◆ Optional feature: Meter counter/512Hz Sonde

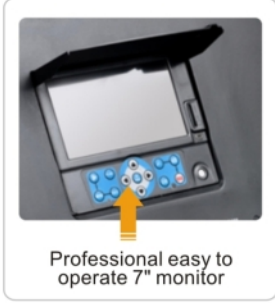

Optional Features & Parts



Specifications

Camera Head		Cable Reel	
Sensor:	1/3" Sony CCD	Material:	Fiberglass rod cable
Head Dimension:	23mm (dia.) x45mm (length)	Wheel:	Stainless steel wheel
Camera Material:	304# Stainless Steel	Cable Length:	20, 30 or 40m optional
View Angle:	120° wide angle	Connector:	Gold touch-point connector
Lens Cover:	Sapphire glass	Rotation:	Rotatable in the suitcase
Leds:	12 High Bright White LEDs	Wheel diameter:	33cm
Water Proof:	IP68/20m under water	Cable diameter:	5.2mm

LCD Display and DVR	
LCD Resolution:	800*480 pixels
Video Compress:	MPEG-4
Recording:	Video and audio recording
Picture:	Picture shot function
LCD Size:	7 inch
Menu Language:	9 Languages
Panel Control:	Any functions through buttons
External Memory:	SD Card (Max. 32GB)



Call: 1 888 434 0253

Contact: Sales@provix.net

Visit: www.provix.net

All-in-One: 3G/WiFi Enabled Vehicle Accident Camera with Live Tracking & Real-Time Image Transfer

KP1S The SmartWitness KP1S is the world's most advanced incident camera with 720p HD video, 3G or WiFi connectivity, live GPS position & driver behavior reports to support post-incident analysis.

Developed to provide evidence of events leading up to and during a road traffic incident, the KP1S provides immediate notifications & photo/video evidence delivered to your desktop in seconds!



- ⦿ Real-time HD image of driver's view -170° angle
- ⦿ Optional 2nd camera for side, rear, driver or cargo view
- ⦿ Video sent in real-time via email or to your telematics system
- ⦿ Dual SD cards for longer recording or redundancy
- ⦿ Instant notification via 3G
- ⦿ Live impact alerting including: location/speed/event footage
- ⦿ Tamper-resistant design, key required to access SD card data

SD Card



KP1S makes constant recordings of video footage and drive data on a loop as the journey continues. This data can be accessed manually at any time by retrieving the KP1S' SD card(s) and inserting into your PC. The included analysis software allows you to view recorded video and drive data evidence of an event. KP1S does not require 3G or WiFi to operate as a stand-alone system.

SmartMail

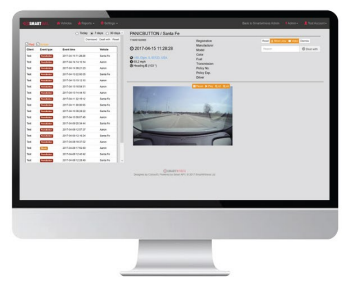

SmartMail was developed with the small/medium fleet operator in mind. It delivers driver safety and protection information to you within moments of an incident taking place. Using KP1 with a cellular modem, safety-critical road events will automatically transmit an email notification with the video clip and event information enclosed. An online portal is provided to help manage all vehicle events.

SmartAPI



SmartWitness enables TSPs (Telematics Services Providers) to pull video, GPS data, audio, & G-Sensor data directly from KP1S and onto your existing Telematics or GPS tracking software. Instead of hosting your own solution with the local server model, your TSP will host it on your behalf and add it to your monthly bill, with the convenience of an integrated system. One invoice, one UI.

PROVIX CAMERA-WASH SYSTEM

PROVIX.NET
Now I CAN SEE!

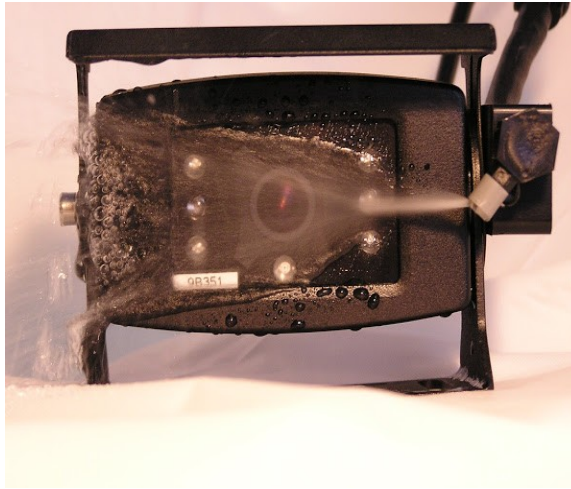
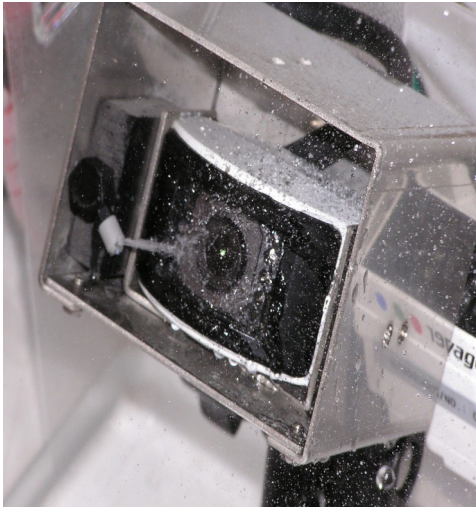

Cleans the Camera lens of Dirt, Ice, Dust and Snow with the push of a button!

KEEP CAMERA LENS CLEAR TO ENHANCE MOBILE SAFETY

- USES WASHER FLUID FOR YEAR ROUND OPERATION.
- 12 VOLT HIGH PRESSURE PUMP
- 1 GALLON RESERVOIR WITH MOUNTING HARDWARE
- MOMENTARY ROCKER SWITCH
- 30 FOOT ELECTRIC HARNESS AND FLUID TUBING KIT. CUSTOM LENGTHS AVAILABLE.
- EASY TO INSTALL
- COMES AS A KIT WITH 30' HARNESS OR CUSTOM LENGTHS ARE AVAILABLE
- OPTIONAL NEMA BOX FOR EASE OF MOUNTING
- ADD UP TO FOUR OPTIONAL NOZZLES PER KIT
- ADD AN OPTIONAL TIMER FOR AUTOMATIC CLEANING.
- ADD A STAINLESS STEEL BOX FOR MOUNTING ON THE SIDE OF OR UNDER SIDE OF PLOW/DUMP TRUCKS.
- CUSTOM KITS AVAILABLE

1-888-434-0253

SALES@PROVIX.NET

WWW.PROVIX.NET



Provix Wireless Communication System

Wireless grab & go system that provides clear, **full duplex** group communication for challenging environments.

- **CLEAR CONTINUOUS SOUND**
- **SECURE COMMUNICATION**
- **INTERFERENCE FREE**
- **EASY to USE & DEPLOY**
- **RUGGED CONSTRUCTION**
- **COMPETITIVELY PRICED**
- **5-man group up to 800 M (2824 ft)**
- **8-man group up to 1900 m (1 mile)**
- **LINE OF SIGHT**
- **PORTABLE**
- **LICENSE FREE**
- **FCC & IC Approved**
- **HEADSETS to SUIT your APPLICATION**



FEATURES:

**Custom configurations
& Headset options**



System improves **safety, efficiency & productivity** for groups working in challenging environments.

Provix Accessories

Ram Mount



Provix Ram mounts are designed to absorb damaging shock and vibration while being ergonomically friendly for multiple viewing and mounting positions.

Quick Disconnect



These weatherproof connectors allow for cable route through bulkheads and allows for easy connections for trailer cameras.

Camera Guard



Provides a stable mounting platform and offer rugged impact protection for cameras.

Camera Wash

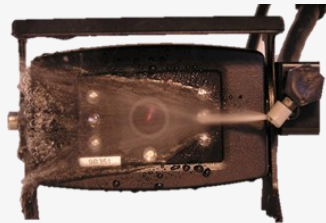

Cleans the camera of dirt, ice, dust and snow with the push of a button.

Monitor Rock Guard



Provides rugged protection for monitors. Provix supplies waterproof monitors: add the rock guard monitor enclosure for a higher level of protection.

DVR Monitor



Monitor with built in DVR, records to SD Card.

Wireless Option



Enables wireless viewing/eliminate cable routing where line of sight can be maintained between transmitter and receiver.



Provix... NOW I CAN SEE

TYPES OF LED AND HID LIGHTING

- REMOTE CONTROLLED SEARCHLIGHT
- SPOT
- PORTABLE / BATTERY OPERATED
- GLARE BUSTERS—ANTI GLARE
- FLOOD
- GRILL LIGHTS
- TAIL LIGHTS
- LIGHT BARS
- STROBE LIGHTS
- WARNING LIGHTS
- ROTATING BEACONS
- WARNING LIGHT STICKS / ARROW BOARD

LIGHTS

Hella, Nordic, VisionX, PSE Amber, Whelen, Provix, JWSpeaker



**Remote Controlled
Searchlights**



**Portable/ Battery
Operated Lights**



Light Bars



**Warning Light Sticks
& Arrow Boards**



Flood/Spot Lights



LED Amber Lights



LED Scene Lighting



LED Work Lights

High Beam: 3,600 Lumens
Low Beam: 1,800 Lumens

FEATURES

- Heated Lens
- SAE/DOT compliant LED Headlight
(High Beam/Low Beam/Turn Signal/Parking)
- Can be mounted on horizontal or vertical surface
- Deutsch Connector
- Pressure Relief Valve

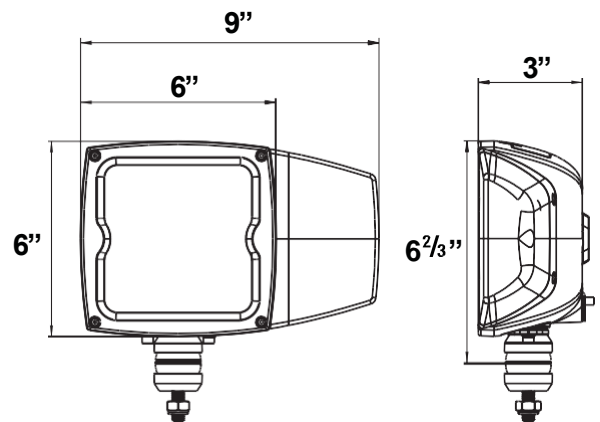

SPECIFICATIONS

- Voltage:** 12V to 30V
- Dimension:** 6" Lx 6" Hx 3" D
- Housing:** Aluminum
- Lens:** Tempered Glass
- EMC:** CE
- IP Rating:** IP68
- RoHS:** Certified

Jobber Price: \$298.00 ea or \$549.00 a pair

Packaging: Color Box



Amber Turn Signal Light
can be mounted left, right or top

OPTIMAL PENETRATION (High Beam): 1,600 ft
OPTIMAL PENETRATION (Low Beam): 980 ft

No Drill Magnetic Mounting Plate

The Provix magnetic mounting plate offers operators a convenient, sturdy and reliable platform to deploy magnetic mount lights of any type. The plate is installed via the rear cab lights and has a weatherproof seal on the back side for secure and dry installation.

Frame Material: Aluminum

Mounting Plate Material: Stainless Steel

Weight: 8 lbs

Mounting Surface Dimensions: 24" x 8"

Installation: Via Rear Cab Lights

Seal: Weatherproof

Finish: Powder Coated - Black, White, or Grey

Compatible Spotlights: Any Magnetic Mount Light

Ratings/Features:

Durable Construction

Stainless Steel Mounting Plate

Works with Any Magnetic Mount Light

Weatherproof Seal

Compatible Vehicle Brands

Chevrolet, Dodge, Ford, GMC, Nissan, Toyota



PROVIX.NET
Now I Can See!

WARNING LIGHTS AND LIGHT BARS

PROVIX Warning Lights and Light Bars are available in various sizes, colours and models. Adding to the visibility of your work area, PROVIX' lights are perfect for your every need. PROVIX' lighting solutions are ready and able to provide and assist with the safety of your work environment when you need it the most.



CALL: 1-888-434-0253 - CONTACT: SALES@PROVIX.NET - VISIT: WWW.PROVIX.NET

40" LED Warning Light Stick - Multiple Pattern

Part No.	Diodes Colour	Diodes	Lens Colour	Flash Pattern	Voltage	Amps	Pkg
PRXE-2940A	Amber	32 x 1W	Amber	8 Patterns	12V - 30V	4.03 @ 12V	Box



- Lamp Dimension : 40"L x 2"H x 2-1/2" D [3" D mounted]
- Aluminium Light Bar with Polycarbonate Lens
- Mounts with "L" or "T" Brackets (included)
- Comes with Control Box for Flash Selection
- 12.8 ft Wire from the Light Bar & 10" Wire from the Control box
- IP 65
- Full Unit Quad Flash & Left/Right Alternating Single Flash

LED Warning Light Set with Small Arrows - Multiple Pattern

Part No.	Diodes Colour	Diodes	Lens Colour	Flash Pattern	Voltage	Amps	Pkg
PRXE-2980A	Amber	48 x 1W	Amber	8 Patterns	12V - 30V	4.62 @ 12V	Box



- Lamp Dimension : 45-1/4"L x 10"H x 2-1/2" D [3" D mounted]
- Aluminium Light Bar with Polycarbonate Lens
- Mount with "L" or "T" Brackets (included)
- Comes with Control Box for Flash Selection
- 12.8 ft Wire from the Light Bar & 10" Wire from the Control box
- Foldable Arrows for Easy Storage
- IP 65
- Full Unit Quad Flash & Left/Right Alternating Single Flash

LED Warning Light Set with Large Arrows - Multiple Pattern

Part No.	Diodes Colour	Diodes	Lens Colour	Flash Pattern	Voltage	Amps	Pkg
PRXE-2990A	Amber	64 x 1W	Amber	8 Patterns	12V - 30V	4.95 @ 12V	Box



- Lamp Dimension : 45-1/4"L x 17-1/2"H x 2-1/2" D [3" D mounted]
- Aluminium Light Bar with Polycarbonate Lens
- Mount with "L" or "T" Brackets (included)
- Comes with Control Box for Flash Selection
- 12.8 ft Wire from the Light Bar & 10" Wire from the Control box
- Foldable Arrows for Easy Storage
- IP 65
- Full Unit Quad Flash & Left/Right Alternating Single Flash

Part No.	Replacement Accessories for PRXE-2940A, PRXE-2980A & PRXE-2990A	Pkg
PRXE-F291	Replacement Control Box	Bulk
PRXE-F292	Replacement "L" Bracket (sold in pairs)	Bag
PRXE-F293	Replacement "T" Bracket (sold in pairs)	Bag
PRXE-F297	13 ft Extension Wire w/ Connectors	Bulk
PRXE-F298	33 ft Extension Wire w/ Connectors	Bulk

9.75" Compact LED - Multiple Pattern

Permanent Mount Models

Part No.	Diodes Colour	Diodes	Lens Colour	Flash Pattern	Voltage	Amps	Pkg
PRXE-2110AC	Amber	30 x 1W	Clear	23 Patterns	12V - 24V	3.8 @ 12V	Box
	Mounting Type		2 Mounting Brackets with Lead Wires				
PRXE-2110ACB	Amber	30 x 1W	Clear	23 Patterns	12V - 24V	3.8 @ 12V	Box
	Mounting Type		Single Bolt Bracket with Lead Wires				

- Lamp Dimension : 9.75" L x 6.77" W x 1.45" H [2" H mounted]
- Polycarbonate Lens & Base
- EMC IPX5
- **SAE J845 Class 1** on all lamp single, quint & ultra flashes
- **SAE J845 Class 2** on all lamp double & quad flashes & 360° rotating flash

Part No.	Accessories for PRXE-2110AC & PRXE-2110ACB	Pkg
PRXF-S955	Fuse/Switch Kit consisting of: PRXST100 On/Off Toggle Switch, PRXST105 On-Off-Momentary On Toggle Switch, PRXATM05 5 Amps Mini Fuse & PRXATMF14C In-Line Fuse Holder w/ Cover	Retail Bag
PRXE-F212	Replacement Brackets (sold in pairs) for PRXE-2110AC	Bulk
PRXE-F211	Replacement Bracket for PRXE-2110ACB	Bulk



PRXE-2110AC

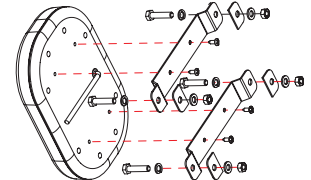

PRXE-2110AC

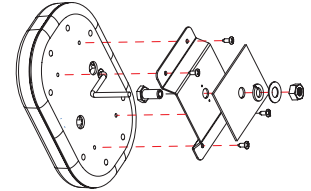

PRXE-2110ACB

Magnetic Mount Model

Part No.	Diodes Colour	Diodes	Lens Colour	Flash Pattern	Voltage	Amps	Pkg
PRXE-2110ACM	Amber	30 x 1W	Clear	23 Patterns	12V - 24V	3.8 @ 12V	Box

- Lamp Dimension : 9.75" L x 6.77" W x 1.45" H [1-13/16" H mounted]
- Polycarbonate Lens & Base
- 4-Magnet Mount, Fused Cigarette Power Adaptor with On/Off Switch, Flash Selection Switch & 9.8 ft of Wire
- EMC IPX5
- **SAE J845 Class 1** on all lamp single, quint & ultra flashes
- **SAE J845 Class 2** on all lamp double & quad flashes & 360° rotating flash

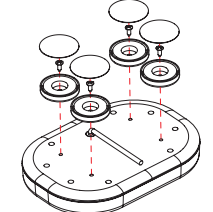

PRXE-2110ACM



PRXE-2110ACM

15" LED Quad Flash (alternating left & right)

Low profile, slim line, aluminium light bar with high output LED diodes.

Magnetic Mount Model

Part No.	Diodes Colour	Diodes	Lens Colour	Flash Pattern	Voltage	Amps	Pkg
PRXE-2150AM	Amber/Amber	32 x 1W	Amber	Quad Alternating Left & Right	12V - 30V	0.74 @ 12V	Box

- Lamp Dimension : 15" L x 3-11/16" W x 1-7/16" H [2-3/16" H mounted]
- Aluminium Light Bar with Polycarbonate Lens
- 2 Magnets with Suction Cups
- Fused Cigarette Power Adaptor with On/Off Switch & 12.5 ft of Wire
- EMC IP65
- **SAE J595 Class 1** (Front & Rear Directional)



PRXE-2150AM

14" Compact LED - Multiple Pattern

Low profile but powerful 360° LED Warning Light Bars. Very bright and complies with SAE Class 1 Standards.

Permanent Mount Model

Part No.	Diodes Colour	Diodes	Lens Colour	Flash Pattern	Voltage	Amps	Pkg
PRXE-2140AC	Amber	24 x 1W	Clear	23 Patterns	12V - 24V	3.8 @ 12V	Box



PRXE-2140AC

- Lamp Dimension : 14" L x 8" W x 2" H
- Polycarbonate Lens & Base
- 1-Bolt Mounting Brackets with Lead Wires
- EMC IPX4K
- **SAE J845 Class 1** on flashes

Part No.	Accessories for PRXE-2140A	Pkg
PRXF-S955	Fuse/Switch Kit consisting of: PRXST100 On/Off Toggle Switch, PRXST105 On-Off-Momentary On Toggle Switch, PRXATM05 5 Amps Mini Fuse & PRXATMF14C In-Line Fuse Holder w/ Cover	Retail Bag

Magnetic Mount Model

Part No.	Diodes Colour	Diodes	Lens Colour	Flash Pattern	Voltage	Amps	Pkg
PRXE-2140ACM	Amber	24 x 1W	Clear	23 Patterns	12V - 24V	3.8 @ 12V	Box



PRXE-2140ACM

- Lamp Dimension : 14" L x 8" W x 2" H
- Polycarbonate Lens & Base
- 2-Magnet Mount, Fused Cigarette Power Adaptor with On/Off Switch, Flash Selection Switch & 9.8 ft of Wire
- EMC IPX4K
- **SAE J845 Class 1** on 3 flashes

16.5" LED Multiple Pattern

Permanent Mount Mode

Part No.	Diodes Colour	Diodes	Lens Colour	Flash Pattern	Voltage	Amps	Pkg
PRXE-2160A	Amber	18 x 1W	Amber	19 Patterns	12V	3.07 @ 12V	Box



PRXE-2160A

- Lamp Dimension : 16-5/8" L x 10-7/8" W x 3" H [3-3/4" H mounted]
- Polycarbonate Lens & Base
- 2 Mounting Brackets with Lead Wires
- EMC IPX5
- **SAE J845 Class 1** on all lamp single & quint flashes
- **SAE J845 Class 2** on all lamp double, quad & ultra flashes

Part No.	Accessories for PRXE-2160A	Pkg
PRXF-S975	Fuse/Switch Kit consisting of: ST100 On/Off Toggle Switch, ST105 On-Off-Momentary On Toggle Switch, ATM075 7.5 Amps Mini Fuse & ATMF14C In-Line Fuse Holder w/ Cover	Retail Bag
PRXE-F216	Replacement Brackets (sold in pairs) for E-2160A	Bulk

16.5" LED Multiple Pattern

Magnetic Mount Model

Part No.	Diodes Colour	Diodes	Lens Colour	Flash Pattern	Voltage	Amps	Pkg
PRXE-2160AM	Amber	18 x 1W	Amber	19 Patterns	12V	3.07 @ 12V	Box

- Lamp Dimension : 16-5/8" L x 6-3/8" W x 3" H [3-1/2" H mounted]
- Polycarbonate Lens & Base
- 4-Magnet Mount, Fused Cigarette Power Adaptor with On/Off Switch, Flash Selection Switch & 11.5 ft of Wire
- EMC IPX5
- **SAE J845 Class 1** on all lamp single & quint flashes
- **SAE J845 Class 2** on all lamp double, quad & ultra flashes



PRXE-2160AM

16.5" LED Quad Flash (alternating left & right)

Permanent Mount Models

Part No.	Diodes Colour	Diodes	Dome/Lens Colour	Flash Pattern	Voltage	Amps	Pkg
PRXE-280AA	Amber/Amber	32 x 1W	Amber	Quad Alternating Left & Right	12V - 30V	1.13 @ 12V	Box
PRXE-280AC	Amber/Amber	32 x 1W	Clear	Quad Alternating Left & Right	12V - 30V	1.13 @ 12V	Box
PRXE-280AW	Amber/White	32 x 1W	Clear	Quad Alternating Left & Right	12V - 30V	1.13 @ 12V	Box

- Lamp Dimension : 16-1/2" L x 8-1/16" W x 4-3/16" H
- Sturdy ABS Base with Polycarbonate Dome & Lens
- Mounting centres 12-5/8" by 6"
- EMC IP65
- PRXE-280AA and PRXE-280AC - **SAE J595 Class 1** (Front & Rear Directional)



PRXE-280AA



PRXE-280AC /E-280AW

Part No.	Accessories for PRXE-280AA, PRXE-280AC & PRXE-280AW	Pkg
PRXF-S950	Fuse/Switch Kit consisting of: PRXST100 On/Off Toggle Switch, PRXATM05 5 Amps Mini Fuse & PRXATMF14C In-Line Fuse Holder w/ Cover	Retail Bag

Magnetic Mount Models

Part No.	Diodes Colour	Diodes	Dome/Lens Colour	Flash Pattern	Voltage	Amps	Pkg
PRXE-280AAM	Amber/Amber	32 x 1W	Amber	Quad Alternating Left & Right	12V - 30V	1.13 @ 12V	Box
PRXE-280ACM	Amber/Amber	32 x 1W	Clear	Quad Alternating Left & Right	12V - 30V	1.13 @ 12V	Box
PRXE-280AWM	Amber/White	32 x 1W	Clear	Quad Alternating Left & Right	12V - 30V	1.13 @ 12V	Box

- Lamp Dimension : 16-1/2" L x 8-1/16" W x 4-3/16" H [4-1/2" H mounted]
- Sturdy ABS Base with Polycarbonate Dome & Lens
- 2 Magnets with Suction Cups
- Fused Cigarette Power Adaptor with On/Off Switch & 11 ft of Wire
- EMC IP65
- PRXE-280AAM and PRXE-280ACM - **SAE J595 Class 1** (Front & Rear Directional)



PRXE-280AAM



PRXE-280ACM /PRXE-280AWM

Low profile, slim line, aluminium light bar with high output LED diodes. Available in 23" and 45" lengths.

23" LED Multiple Pattern

Permanent Mount Model

Part No.	Diodes Colour	Diodes	Lens Colour	Flash Pattern	Voltage	Amps	Pkg
PRXE-2230A	Amber/Amber	40 x 1W	Amber	8 Patterns	12V - 30V	3.49 @ 12V	Box



PRXE-2230A

- Lamp Dimension : 23" L x 3-11/16" W x 1-7/16" H [3-7/8" H mounted w/ brackets]
- Aluminium Light Bar with Polycarbonate Lens
- Complete with adjustable mounting brackets and control box for flash pattern selection
- 12 ft Wire from the Light Bar & 6" Wire from the Control box
- ECM IP65
- **SAE J595** (Front & Rear Directional) - **Class 1** on 1 flash & Class 2 on other flashes

PRXE-2232AM



PRXE-F200-8



PRXE-F255

Part No.	Accessories for PRXE-2230A	Pkg
PRXE-F255	Low Profile Aluminium Brackets (sold in pairs) to reach mounted height of 2" only Bracket Dimension : 5-3/16" L x 3/4" W x 9/16" H Mounting Holes : Two 7/32" holes at 4-3/4" centres	Retail Bag
PRXE-F065-8	6.5 ft Extension Wires w/ Connectors (8-Pin) for PRXE-2230A	Bulk
PRXE-F260-8	26 ft Extension Wires w/ Connectors (8-Pin) for PRXE-2230A	Bulk
PRXE-F200-8	Replacement Control Box (8-Pin)	Bulk
PRXE-F250	Replacement Mounting Brackets (sold in pairs)	Bulk

Magnetic Mount Models

Part No.	Diodes Colour	Diodes	Lens Colour	Flash Pattern	Voltage	Amps	Pkg
PRXE-2232AM	Amber/Amber	40 x	Amber	12 Patterns	12V - 30V	0.92 @ 12V	Box
PRXE-2232ACM	Amber/Amber	40 x	Clear	12 patterns	12V - 30V	0.92 @ 12V	Box
PRXE-2232AWM	Amber/White	40 x	Clear	12 Patterns	12V - 30V	1.61 @ 12V	Box



PRXE-2232AM



PRXE-2232ACM / PRXE-2232AWM

- Lamp Dimension : 23" L x 3-11/16" W x 1-7/16" H [2-3/16" H mounted]
- Aluminium Light Bar with Polycarbonate Lens
- 2 Magnets with Suction Cups
- Fused Cigarette Power Adaptor with Switch for Flash Pattern Selection & 12.5 ft of Wire
- EMC IP65

45" LED Multiple Pattern

Permanent Mount Model

Part No.	Diodes Colour	Diodes	Lens Colour	Flash Pattern	Voltage	Amps	Pkg
PRXE-2450A	Amber/Amber	72 x 1W	Amber	8 Patterns	12V - 30V	5.55 @ 12V	Box



PRXE-2450A

- Lamp Dimension : 45" L x 3-11/16" W x 1-7/16" H [3-7/8" H mounted w/ brackets]
- Aluminium Light Bar with Polycarbonate Lens
- Complete with adjustable mounting brackets and control box for flash pattern selection
- 12 ft Wire from the Light Bar & 6" Wire from the Control box
- EMC IP65
- **SAE J595** (Front & Rear Directional) - **Class 1** on 1 flash & Class 2 on other flashes



PRXE-F200-8



PRXE-F700-2 Mounted



PRXE-F255

Part No.	Accessories for PRXE-2450A	Pkg
PRXE-F700-2	Plated Steel Extension Plate (sold in pairs) to extend length of light bar to fit larger pick up trucks, such as Ford 250 Plate Dimension : 16" L x 2" W	Bulk
PRXE-F255	Low Profile Aluminium Brackets (sold in pairs) to reach mounted height of 2" only Bracket Dimension : 5-3/16" L x 3/4" W x 9/16" H Mounting Holes : Two 7/32" holes at 4-3/4" centres	Retail Bag
PRXE-F065-8	6.5 ft Extension Wires w/ Connectors (8-Pin) for PRXE-2450A	Bulk
PRXE-F260-8	26 ft Extension Wires w/ Connectors (8-Pin) for PRXE-2450A	Bulk
PRXE-F200-8	Replacement Control Box (8-Pin)	Bulk
PRXE-F250	Replacement Mounting Brackets (sold in pairs)	Bulk

Compact Low Profile - Multiple Pattern

Compact but powerful directional LED Warning Lights. Low profile - about 3/4" in height. Very bright and complies with SAE Class 1 standards. Various mounting brackets available for PRXE-915 series - easily mounts on every application : surface mount, grill mount, dash mount or head liner mount.

Part No.	Diodes Colour	Diodes	Lens Colour	Flash Pattern	Voltage	Amps	Pkg
PRXE-915AA	Amber/Amber	6	Clear	19 Patterns	12V - 24V	0.50 @ 12V	Retail Bag
PRXE-915AW	Amber/White	6	Clear	19 Patterns	12V - 24V	0.70 @ 12V	Retail Bag
PRXE-915WW	White/White	6	Clear	19 Patterns	12V - 24V	0.80 @ 12V	Retail Bag
PRXE-915BB	Blue/Blue	6	Clear	19 Patterns	12V - 24V	0.57 @ 12V	Retail Bag
PRXE-915BR	Blue/Red	6	Clear	19 Patterns	12V - 24V	0.55 @ 12V	Retail Bag
PRXE-915GG	Green/Green	6	Clear	19 Patterns	12V - 24V	0.46 @ 12V	Retail Bag
PRXE-915RR	Red/Red	6	Clear	19 Patterns	12V - 24V	0.61 @ 12V	Retail Bag



PRXE-915 Side



PRXE-915

- Lamp Dimension : 5" L x 1" W x 11/16" H
- Black Powder Coated Aluminium Base & Polycarbonate Lens
- Surface mount - 2 holes @ 4-3/4" centres
- Lights can be synchronized using yellow wire
- EMC IPX7
- PRXE-915AA, PRXE-915WW, PRXE-915BB and PRXE-915RR : **SAE J595 Class 1** on 5 flashes

Part No.	Accessories for PRXE-915 series	Pkg
PPRXF-S935	Fuse/Switch Kit consisting of: PRXST100 On/Off Toggle Switch, PRXST108 Momentary On-Off Toggle Switch PRXATS03 3 Amps Standard Fuse & PRXATSF14C In-Line Fuse Holder w/ Cover	Retail Bag
PRXE-F951	"L" Bracket for mounting single PRXE-915	Bulk
PRXE-F952	"L" Bracket for mounting double PRXE-915	Bulk
PRXE-F953	"T" Bracket for mounting PRXE-915	Bulk
PRXE-F954	Adjustable Swivel Bracket	Bulk



PRXE-F951



PRXE-F952



PRXE-F953



PRXE-F954

Part No.	Diodes Colour	Diodes	Lens Colour	Flash Pattern	Voltage	Amps	Pkg
PRXE-913A	Amber	3	Clear	12 Patterns	12V - 24V	0.29 @ 12V	Retail Bag
PRXE-913W	White	3	Clear	12 Patterns	12V - 24V	0.42 @ 12V	Retail Bag

- Lamp Dimension : 3-5/16" L x 1-1/8" W x 11/16" H
- Black Powder Coated Aluminium Base & Polycarbonate Lens
- Surface mount - 2 holes @ 3-1/16" centres
- Lights can be synchronized using yellow wire
- EMC IPX7
- **SAE J595 Class 2** on 7 flashes



PRXE-913

Part No.	Accessories for PRXE-913 series	Pkg
PPRXF-S935	Fuse/Switch Kit consisting of: PRXST100 On/Off Toggle Switch, PRXST108 Momentary On-Off Toggle Switch PRXATS03 3 Amps Standard Fuse, PRXATSF14C In-Line Fuse Holder w/ Cover	Retail Bag

LED Quad Flash (Strobe)



PRXE-950A



PRXE-950CA



PRXE-950G



PRXE-950CG



PRXE-950B



PRXE-950CW



PRXE-950R

Part No.	Diodes Colour	Diodes	Lens Colour	Flash Pattern	Voltage	Amps	Pkg
PRXE-950A	Amber	4	Amber	Quad	9V - 36V	0.40 @ 12V	Retail Bag
PRXE-950CA	Amber	4	Clear	Quad	9V - 36V	0.40 @ 12V	Retail Bag

- Lamp Dimension : 4-3/4" L x 1-7/8" W x 1-5/8" H
- Aluminium Die Cast Base & Polycarbonate Lens
- Surface mount - 2 holes @ 4-1/2" centres
- EMC IP67
- **SAE J595 Class 2**

Part No.	Diodes Colour	Diodes	Lens Colour	Flash Pattern	Voltage	Amps	Pkg
PRXE-950G	Green	4	Green	Quad	9V - 36V	0.40 @ 12V	Retail Bag
PRXE-950CG	Green	4	Clear	Quad	9V - 36V	0.40 @ 12V	Retail Bag

- Lamp Dimension : 4-3/4" L x 1-7/8" W x 1-5/8" H
- Aluminium Die Cast Base & Polycarbonate Lens
- Surface mount - 2 holes @ 4-1/2" centres
- EMC IP67

Part No.	Diodes Colour	Diodes	Lens Colour	Flash Pattern	Voltage	Amps	Pkg
PRXE-950B	Blue	4	Blue	Quad	9V - 36V	0.30 @ 12V	Retail Bag
PRXE-950CW	White	4	Clear	Quad	9V - 36V	0.40 @ 12V	Retail Bag
PRXE-950R	Red	4	Red	Quad	9V - 36V	0.30 @ 12V	Retail Bag

- Lamp Dimension : 4-3/4" L x 1-7/8" W x 1-5/8" H
- Aluminium Die Cast Base & Polycarbonate Lens
- Surface mount - 2 holes @ 4-1/2" centres
- EMC IP67
- **SAE J595 Class 2**

Part No.	Accessories for PRXE-950 Series	Pkg
PRXF-S950	Fuse/Switch Kit consisting of: PRXST100 On/Off Toggle Switch, PRXATM05 5 Amps Mini Fuse & PRXATMF14C In-Line Fuse Holder w/ Cover	Retail Bag

LED White Steady Utility Light



PRXE-955C

Part No.	Diodes Colour	Diodes	Lens Colour	Pattern	Voltage	Amps	Pkg
PRXE-955C	White	4	Clear	Steady	12V	0.50	Retail Bag

- Lamp Dimension : 4-3/4" L x 1-7/8" W x 1-5/8" H
- Aluminium Die Cast Base & Polycarbonate Lens
- Surface mount - 2 holes @ 4-1/2" centres
- IP67

4" Round LED Quad Flash (Strobe)

PRXE-940 has the same dimension as a 4" tail lamp. Use regular open or closed back grommets and double contact pigtails. Convenient and easy to install. Lamp kits with grommet, pigtail & mounting bracket available for instant installation. Also available in rubber housing just like a work lamp for permanent mount or magnetic mount.

Part No.	Diodes Colour	Diodes	Lens Colour	Flash Pattern	Voltage	Amps	Pkg
PRXE-940A	Amber	24	Amber	Quad	9V - 36V	0.38 @ 12V	Retail Bag
PRXE-940CA	Amber	24	Clear	Quad	9V - 36V	0.38 @ 12V	Retail Bag
PRXE-940B	Blue	24	Blue	Quad	9V - 36V	0.38 @ 12V	Retail Bag
PRXE-940R	Red	24	Red	Quad	9V - 36V	0.38 @ 12V	Retail Bag

- Lamp Dimension : 4-1/4" Dia x 1-3/4" H
- Polycarbonate Lens & Body
- EMC IP67
- SAE J595 Class 2

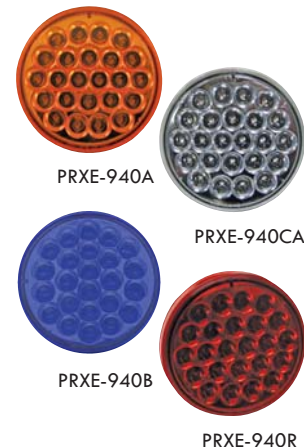

Part No.	Kits for Instant Installation:	Pkg
PRXE-940A-K	with Open Back Grommet & Double Contact Pigtail	Retail Bag
PRXE-940CA-K	with Open Back Grommet & Double Contact Pigtail	Retail Bag
PRXE-940B-K	with Open Back Grommet & Double Contact Pigtail	Retail Bag
PRXE-940R-K	with Open Back Grommet & Double Contact Pigtail	Retail Bag
PRXE-940A-KM	with Black Steel Mounting Bracket, Open Back Grommet & Double Contact Pigtail	Retail Bag
PRXE-940CA-KM	with Black Steel Mounting Bracket, Open Back Grommet & Double Contact Pigtail	Retail Bag
PRXE-940B-KM	with Black Steel Mounting Bracket, Open Back Grommet & Double Contact Pigtail	Retail Bag
PRXE-940R-KM	with Black Steel Mounting Bracket, Open Back Grommet & Double Contact Pigtail	Retail Bag



Part No.	Rubber Lamp Assembly	Pkg
PRXEH-940A	in Rubber Housing	Retail Bag
PRXEH-940CA	in Rubber Housing	Retail Bag
PRXEH-940B	in Rubber Housing	Retail Bag
PRXEH-940R	in Rubber Housing	Retail Bag



Part No.	Magnetic Mount Rubber Lamp Assembly	Pkg
PRXEHM-940A	in Rubber Housing with Magnetic Base & Fused Cigarette Power Adaptor	Retail Bag
PRXEHM-940CA	in Rubber Housing with Magnetic Base & Fused Cigarette Power Adaptor	Retail Bag
PRXEHM-940B	in Rubber Housing with Magnetic Base & Fused Cigarette Power Adaptor	Retail Bag
PRXEHM-940R	in Rubber Housing with Magnetic Base & Fused Cigarette Power Adaptor	Retail Bag



Part No.	Accessories for PRXE-940 series	Pkg
PRXF-S950	Fuse/Switch Kit consisting of: PRXST100 On/Off Taggle Switch, PRXATMO5 5 Amps Mini Fuse & PRXATMF14C In-Line Fuse Holder w/ Cover	Retail Bag

PRXE-920 & PRXE-921 are the same dimensions as an oval tail lamp. Use regular open or closed back grommets and double contact pigtails. Convenient and easy to install. Lamp kits with grommet, pigtail & mounting bracket available for instant installation.

Oval LED Quad Flash (Strobe)



PRXE-920A



PRXE-920CA



PRXE-920B



PRXE-920R

Part No.	Diodes Colour	Diodes	Lens Colour	Flash Pattern	Voltage	Amps	Pkg
PRX-920A	Amber	24	Amber	Quad	9V - 36V	0.38 @ 12V	Retail Bag
PRXE-920CA	Amber	24	Clear	Quad	9V - 36V	0.38 @ 12V	Retail Bag
PRXE-920B	Blue	24	Blue	Quad	9V - 36V	0.38 @ 12V	Retail Bag
PRXE-920R	Red	24	Red	Quad	9V - 36V	0.38 @ 12V	Retail Bag

- Lamp Dimension : 6-1/2" L x 2-1/4" W x 1-3/4" H
- Polycarbonate Lens & Body
- EMC IP67
- **SAE J595 Class 2**



PRXE-920R-K



PRXE-920A-KM



PRXE-920CA-KM

Part No.	Kits for Instant Installation:	Pkg
PRXE-920A-K	with Open Back Grommet & Double Contact Pigtail	Retail Bag
PRXE-920CA-K	with Open Back Grommet & Double Contact Pigtail	Retail Bag
PRXE-920B-K	with Open Back Grommet & Double Contact Pigtail	Retail Bag
PRXE-920R-K	with Open Back Grommet & Double Contact Pigtail	Retail Bag
PRXE-920A-KM	with Black Steel Mounting Bracket, Open Back Grommet & Double Contact Pigtail	Retail Bag
PRXE-920CA-KM	with Black Steel Mounting Bracket, Open Back Grommet & Double Contact Pigtail	Retail Bag
PRXE-920B-KM	with Black Steel Mounting Bracket, Open Back Grommet & Double Contact Pigtail	Retail Bag
PRXE-920R-KM	with Black Steel Mounting Bracket, Open Back Grommet & Double Contact Pigtail	Retail Bag

Part No.	Accessories for PRXE-920 series	Pkg
PRXF-S950	Fuse/Switch Kit consisting of: PRXST100 On/Off Toggle Switch, PRXATM05 5 Amps Mini Fuse & PRXATMF14C In-Line Fuse Holder w/ Cover	Retail Bag

Oval LED Sequential Flashing (Arrows)



PRXE-921A



PRXE-921A-K



PRXE-921A-KM

Part No.	Diodes Colour	Diodes	Lens Colour	Flash Pattern	Voltage	Amps	Pkg
PRXE-921A	Amber	35	Amber	Sequential	9V - 36V	0.38 @ 12V	Retail Bag

- Lamp Dimension : 6-1/2" L x 2-1/4" W x 2" H
- Polycarbonate Lens & Body
- Sequential Flash Fills Lamp and Repeats
- EMC IP67

Part No.	Kits for Instant Installation:	Pkg
PRXE-921A-K	E-921A with Open Back Grommet & Double Contact Pigtail	Retail Bag
PRXE-921A-KM	E-921A with Black Steel Mounting Bracket, Open Back Grommet & Double Contact Pigtail	Retail Bag

Part No.	Accessories for PRXE-921 series	Pkg
PRXF-S950	Fuse/Switch Kit consisting of: PRXST100 On/Off Toggle Switch, PRXATM05 5 Amps Mini Fuse & PRXATMF14C In-Line Fuse Holder w/ Cover	Retail Bag

Heavy Duty LED Quad Flash (Strobe)

Part No.	Colour	Diodes	Flash Pattern	Voltage	Amps	Pkg
PRXE-888AC	Amber	8 High Output Diodes	Quad	12V - 40V	1.30 @ 12V	Box

- Lamp Dimension : 7-1/2" H x 8-3/4" Base Dia
- Aluminium Base with Polycarbonate Amber Lens & Clear Dome
- Mounting Options : 3-1/2" center or 7" center
- IP65
- **SAE J845 Class 1**



PRXE-888AC

Part No.	Colour	Diodes	Flash Pattern	Voltage	Amps	Pkg
PRXE-880AC	Amber	120	Quad	12V	0.87	Box

- Lamp Dimension : 7-1/2" H x 8-3/4" Base Dia
- Aluminium Base with Polycarbonate Amber Lens & Clear Dome
- Mounting Options : 3-1/2" center or 7" center
- EMC IP65
- **SAE J845 Class 2**



PRXE-880AC

Part No.	Accessories for PRXE-888AC & PRXE-880AC	Pkg
PRXF-S950	Fuse/Switch Kit consisting of: PRXST100 On/Off Toggle Switch, PRXATM05 5 Amps Mini Fuse & PRXATMF14C In-Line Fuse Holder w/ Cover	Retail Bag
PRXF-F680	Mounting Plate & Bracket Set for mounting on pole or mirror arm	Bulk

Combination LED Quad Flash (Strobe) & LED Rotating

Part No.	Colour	Diodes	Flash Pattern	Voltage	Amps	Pkg
PRXE-658A	Amber	8 High Output Diodes	Quad / Rotating	12V - 50V	1.50 @ 12V	Box

- Lamp Dimension : 4-1/2" H x 6-1/2" Base Dia
- Aluminium Base & Polycarbonate Lens
- **Switch (PRXST109) Included** for Flash Pattern Selection
- 3 Mounting Holes on 6" diameter
- IP65
- **SAE J845 Class 1** on Quad Flash
- **SAE J845 Class 2** on Rotating Flash



PRX-658A

Part No.	Accessories for PRXE-658A	Pkg
PRXE-S950	Fuse/Switch Kit consisting of: PRXST100 On/Off Toggle Switch, PRXATM05 5 Amps Mini Fuse & PRXATMF14C In-Line Fuse Holder w/ Cover	Retail Bag
PRXE-F680	Mounting Plate & Bracket Set for mounting on pole or mirror arm	Bulk
PRXE-FM600	Magnet Mount Kit w/ Coiled Wire and Fused Cigarette Power Adaptor to convert lamp to magnetic mount	Bulk

LED Rotating Flash



PRXE-650 A

Part No.	Colour	Diodes	Flash Pattern	Voltage	Amps	Pkg
PRXE-650A	Amber	8 High Output Diodes	Rotating	12V - 40V	0.60 @ 12V	Box

- Lamp Dimension : 5" H x 6-1/2" Base Dia
- Sturdy ABS Base & Polycarbonate Lens
- 3 Mounting Holes on 6" diameter
- IP65
- **SAE J845 Class 2**

Part No.	Accessories for PRXE-650A	Pkg
PRXF-S950	Fuse/Switch Kit consisting of: PRXST100 On/Off Toggle Switch, PRXATM05 5 Amps Mini Fuse & PRXATMF14C In-Line Fuse Holder w/ Cover	Retail Bag
PRXF-F680	Mounting Plate & Bracket Set for mounting on pole or mirror arm	Bulk
PRXF-FM600	Magnet Mount Kit w/ Coiled Wire and Fused Cigarette Power Adaptor to convert lamp to magnetic mount	Bulk

LED Quad Flash (Strobe)



PRXE-550A

Part No.	Colour	Diodes	Flash Pattern	Voltage	Amps	Pkg
PRXE-550A	Amber	120	Quad	12V	0.87	Box

- Lamp Dimension : 5" H x 6.3" Base Dia
- Sturdy ABS Base & Polycarbonate Lens
- 3 Mounting Holes on 6" diameter
- EMC IP65
- **SAE J845 Class 2**



PRXE-550AT Pole Mount

PRXE-550AT Surface Mount

Part No.	Colour	Diodes	Flash Pattern	Voltage	Amps	Pkg
PRXE-550AT	Amber	120	Quad	12V	0.87	Box

- Lamp Dimension : 5" H x 6.3" Base Dia
- Black Enamel Aluminium Base with Chrome Ring
- Pole Mount use 1" pipe thread NPT (pipe not included)
- 3 Mounting Holes on 6" diameter
- EMC IP65
- **SAE J845 Class 2**



PRXE-553A

Part No.	Colour	Diodes	Flash Pattern	Voltage	Amps	Pkg
PRXE-553A	Amber	8 High Output Diodes	Quad	12V	0.96 @ 12V	Box

- Lamp Dimension : 5" H x 6.5" Base Dia
- Sturdy ABS Base & Polycarbonate Lens
- 3 Mounting Holes on 6" diameter
- IP66
- **SAE J845 Class 2**

Part No.	Accessories for PRXE-550A, PRXE-550AT & PRXE-553A	Pkg
PRXF-S950	Fuse/Switch Kit consisting of: PRXST100 On/Off Toggle Switch, PRXATM05 5 Amps Mini Fuse & PRXATMF14C In-Line Fuse Holder w/ Cover	Retail Bag
PRXF-F680	Mounting Plate & Bracket Set for mounting on pole or mirror arm	Bulk
PRXF-FM600	Magnet Mount Kit w/ Coiled Wire and Fused Cigarette Power Adaptor to convert lamp to magnetic mount	Bulk

LED Quad Flash (Strobe)

Permanent Mount Model

Part No.	Colour	Diodes	Flash Pattern	Voltage	Amps	Pkg
PRXE-330A	Amber	30	Quad	12V - 40V	0.14 @ 12V	Box
PRXE-330W	White	30	Quad	12V - 40V	0.14 @ 12V	Box

- Lamp Dimension : 3-3/4" H x 5" Base Dia
- Sturdy ABS Base & Polycarbonate Lens
- 3 Mounting Holes on 4-3/4" diameter
- IP66

Part No.	Accessories for PRXE-330A	Pkg
PRXF-S950	Fuse/Switch Kit consisting of: PRXST100 On/Off Toggle Switch, PRXATM05 5 Amps Mini Fuse & PRXATMF14C In-Line Fuse Holder w/ Cover	Retail Bag
PRXF-F680	Mounting Plate & Bracket Set for mounting on pole or mirror arm	Bulk



Magnetic Mount Models

Part No.	Colour	On/Off Switch	Diodes	Flash Pattern	Voltage	Amps	Pkg
PRXE-330AM	Amber	No	30	Quad	12V - 40V	0.14 @ 12V	Box
PRXE-332AM	Amber	Yes	30	Quad	12V - 24V	0.14 @ 12V	Box
PRXE-330BM	Blue	No	30	Quad	12V - 40V	0.14 @ 12V	Box

- Lamp Dimension : 3-3/4" H x 5" Base Dia
- Magnetic Base with Fused Cigarette Power Adaptor & Polycarbonate Lens
- IP66



LED Rotating Flash

Part No.	Colour	Diodes	Flash Pattern	Voltage	Amps	Pkg
PRXE-350A	Amber	30	Rotating	12V	0.10	Box

- Lamp Dimension : 4" H x 5" Base Dia
- Sturdy ABS Base & Polycarbonate Lens
- 3 Mounting Holes on 4-5/8" diameter
- IP66

Part No.	Accessories for PRXE-350A	Pkg
PRXF-S950	Fuse/Switch Kit consisting of: PRXST100 On/Off Toggle Switch, PRXATM05 5 Amps Mini Fuse & PRXATMF14C In-Line Fuse Holder w/ Cover	Retail Bag
PRXF-F680	Mounting Plate & Bracket Set for mounting on pole or mirror arm	Bulk
PRXF-FM600	Magnet Mount Kit w/ Coiled Wire and Fused Cigarette Power Adaptor to convert lamp to magnetic mount	Bulk



Battery Operated LED Rotating

Part No.	Colour	Diodes	Flash Pattern	Mounting	Pkg
PRXE-480AM	Amber	20	Rotating	Magnetic Base	Box
PRXE-480BM	Blue	20	Rotating	Magnetic Base	Box
PRXE-480AB	Amber	20	Rotating	Bracket Mount	Box

- Lamp Dimension : 4-1/2" H x 5" Base Dia
- Comes with On/Off Switch
- Use 4 AA Batteries (not included)
- IP65



Battery Operated LED (Strobe)



PRXE-420AM

Part No.	Colour	Diodes	Flash Pattern	Mounting	Pkg
PRXE-420AM	Amber	4	Single	Magnetic Base	Box

- Lamp Dimension : 4" H x 4-3/4" Base Dia
- Comes with On/Off Switch
- Use 2 AA Batteries (not included)
- IP65



PRXE-450AM

Part No.	Colour	Diodes	Flash Pattern	Mounting	Pkg
PRXE-450AM	Amber	30	Quad	Magnetic Base	Box

- Lamp Dimension : 5" H x 4-3/4" Base Dia
- Comes with On/Off Switch
- Use 9V Battery (not included)

Multiple Pattern LED Mini Dual Warning Light Sets

Each set contains 2 LED synchronized strobe heads. Strobe heads can be mounted inside head or tail lamp assemblies or surface mounted. All necessary mounting hardware included.



PRXE-985AK
LED Strobe Heads

Part No.	Diodes Colour	Diodes	Lens Colour	Flash Pattern	Voltage	Amps	Pkg
PRXE-985AK	Amber	6	Amber	19 Patterns	12V	0.7	Box
PRXE-985CAK	Amber	6	Clear	19 Patterns	12V	0.7	Box
PRXE-985CWK	White	6	Clear	19 Patterns	12V	0.7	Box
PRXE-985BK	Blue	6	Blue	19 Patterns	12V	0.7	Box



Control Box



Extension Wire



Gaskets & Screws



Black Flanges



Taggle Switch

- Each Light Set consists of:
 - 2 LED Strobe Heads in Chrome Aluminium Base & Polycarbonate Lens
 - 2 Black Flanges
 - Control Box with 36" Wire Harness at Each End
 - 80" Extension Wire Harness
 - Momentary On-Off Chrome Toggle (PRXST108) for Flash Pattern Selection - Gaskets & Screws
- Lamp Dimension : 1-1/2" Dia x 1-1/16" H
- Mounting Holes : 2 holes @ 1-9/32 centers
- IPX7

Part No.	Accessories for PRXE-958 series	Pkg
PRXF-S950	Fuse/Switch Kit consisting of: PRXST100 On/Off Toggle Switch, PRXATM05 5 Amps Mini Fuse & PRXATMF14C In-Line Fuse Holder w/ Cover	Retail Bag
PRXE-F985-5	Chrome Flange	Retail Bag

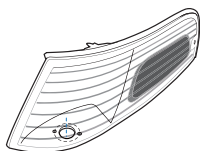

Headlamp/Tail lamp
Assembly Mount

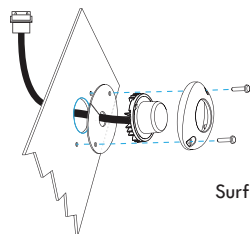

Surface Mount

Heavy Duty Strobe

Part No.	Colour	Flash Pattern	Joules	Voltage	Amps	Pkg
PRXC-883AC	Amber	Double/Quad SAE J845 Class 2	17	12V - 24V	2.21 @ 12V	Box
PRXC-880BC	Blue	Single/Quad Quad - SAE J1318 Class 2 Single - SAE J1318 Class 3	14	12V - 48V	2.0 @ 12V	Box

- Lamp Dimension : 7-1/2" H x 8-3/4" Base Dia
- Aluminium Base with Polycarbonate Lens & Clear Dome
- Mounting Options : 3-1/2" center or 7" center
- EMC IP65



PRXC-883AC

Part No.	Accessories for PRXC-883AC & PRXC-880BC	Pkg
PRXF-S950	Fuse/Switch Kit consisting of: PRXST100 On/Off Toggle Switch, PRXATM05 5 Amps Mini Fuse & PRXATMF14C In-Line Fuse Holder w/ Cover	Retail Bag
PRXF-F680	Mounting Plate & Bracket Set for mounting on pole or mirror arm	Bulk
PRXCB-883	Replacement Flash Bulb for PRXC-883AC	Clamshell
PRXCB-880	Replacement Flash Bulb for PRXC-880BC	Clamshell
PRXCC-880	Replacement Clear Dome	Bulk
PRXCL-550A	Replacement Amber Lens for	Bulk
PRXCL-550B	Replacement Blue Lens for	Bulk



PRXC-880BC

Part No.	Colour	Flash Pattern	Joules	Voltage	Amps	Pkg
PRXC-553A	Amber	Double/Quad SAE J845 Class 2 w/ High/Low Intensity Option	17	12V - 24V	2.21 @ 12V	Box

- Lamp Dimension : 4-3/4" H x 6-7/16" Base Dia
- Aluminium Base & Polycarbonate Lens
- Mounting:
Surface Mount - 3 Mounting Holes (3/16") on 6" centres
Pole Mount use 1" pipe thread NPT (pipe not included)
- EMC IP66



PRXC-553A



PRXC-553A Base Surface or Pole Mount

Part No.	Colour	Flash Pattern	Joules	Voltage	Amps	Pkg
PRXC-550A	Amber	Double/Quad Double - SAE J1318 Class 2 Quad - SAE J1318 Class 3	12	12V - 48V	2.0 @ 12V	Box
PRXC-550B	Blue	Double/Quad	12	12V - 48V	2.0 @ 12V	Box

- Lamp Dimension : 5" H x 6-1/2" Base Dia
- Sturdy ABS Base & Polycarbonate Lens
- 3 Mounting Holes on 6" diameter
- EMC IP66



PRXC-550A



PRXC-550B

Part No.	Accessories for PRXC-553A, PRXC-550A & PRXC-550B	Pkg
PRXF-S950	Fuse/Switch Kit consisting of: PRXST100 On/Off Toggle Switch, PRXATM05 5 Amps Mini Fuse & PRXATMF14C In-Line Fuse Holder w/ Cover	Retail Bag
PRXF-F680	Mounting Plate & Bracket Set for mounting on mirror arm	Bulk
PRXF-FM600	Magnet Mount Kit w/ Coiled Wire and Fused Cigarette Power Adaptor to convert lamp to magnetic mount	Bulk
PRXCB-553	Replacement Flash Bulb for PRXC-553A	Clamshell
PRXCB-550	Replacement Flash Bulb for PRXC-550A & PRXC-550B	Clamshell
PRXCL-553A	Replacement Amber Lens for PRXC-553A	Bulk
PRXCL-550A	Replacement Amber Lens for PRXC-550A	Bulk
PRXCL-550B	Replacement Blue Lens for PRXC-550B	Bulk



PRXC-450AD

Part No.	Colour	Flash Pattern	Joules	Voltage	Amps	Pkg
PRXC-450AD	Amber	Single	3	12V - 48V	0.3 @ 12V	Box
PRXC-450BD	Blue	Single	3	12V - 48V	0.3 @ 12V	Box

- Lamp Dimension : 4-1/2" H x 5-1/2" Base Dia
- Rubber Base & Polycarbonate Lens
- 2 Mounting Studs (#8 screws) on 4" center
- IP65



PRXC-450BD

Part No.	Accessories for PRXC-450AD & PRXC-450BD	Pkg
PRXF-S950	Fuse/Switch Kit consisting of: PRXST100 On/Off Toggle Switch, PRXATM05 5 Amps Mini Fuse & PRXATMF14C In-Line Fuse Holder w/ Cover	Retail Bag
PRXCB-450	Replacement Flash Bulb for PRXC-450AD & PRXC-450BD	Clamshell
PRXCL-550A	Replacement Amber Lens for PRXC-450AD	Bulk
PRXCL-550B	Replacement Blue Lens for PRXC-450BD	Bulk

PRXC-330B



PRXC-330A

Permanent Mount Models

Part No.	Colour	Flash Pattern	Joules	Voltage	Amps	Pkg
PRXC-330A	Amber	Single	2	12V - 120V	0.25 @ 12V	Box
PRXC-330B	Blue	Single	2	12V - 120V	0.25 @ 12V	Box

- Lamp Dimension : 4" H x 5" Base Dia
- Sturdy ABS Base & Polycarbonate Lens
- 3 Mounting Holes on 4-3/4" diameter
- EMC IP66

Part No.	Accessories for PRXC-330A & PRXC-330B	Pkg
PRXF-S950	Fuse/Switch Kit consisting of: PRXST100 On/Off Toggle Switch, PRXATM05 5 Amps Mini Fuse & PRXATMF14C In-Line Fuse Holder w/ Cover	Retail Bag
PRXF-F680	Mounting Plate & Bracket Set for mounting on pole or mirror arm	Bulk
PRXCB-330	Replacement Flash Bulb for PRXC-330A & PRXC-330B	Clamshell
PRXCL-330A	Replacement Amber Lens for PRXC-330A	Bulk
PRXCL-330B	Replacement Blue Lens for PRXC-330B	Bulk



PRXC-330AM



PRXC-330BM

Magnetic Mount Models

Part No.	Colour	Flash Pattern	Joules	Voltage	Amps	Pkg
PRXC-330AM	Amber	Single	2	12V - 120V	0.25 @ 12V	Box
PRXC-330BM	Blue	Single	2	12V - 120V	0.25 @ 12V	Box

- Lamp Dimension : 4" H x 5" Base Dia
- Magnetic Base with Power Adaptor Polycarbonate Lens
- EMC IP66

Part No.	Accessories for PRXC-330AM & PRXC-330BM	Pkg
PRXCB-330	Replacement Flash Bulb for PRXC-330AM & PRXC-330BM	Clamshell
PRXCL-330A	Replacement Amber Lens for PRXC-330AM	Bulk
PRXCL-330B	Replacement Blue Lens for PRXC-330BM	Bulk

Towmotor Application Strobe

Part No.	Colour	Flash Pattern	Joules	Voltage	Amps	Pkg
PRXC-250A	Amber	Single	2	12V - 120V	0.24 @ 12V	Box

- Lamp Dimension : 5" H x 2-3/4" Base Dia
- Mounting : 3-3/8" centre
- Mounting Hole : 3/16"
- ABS Base & Polycarbonate Lens
- EMC IP66

Part No.	Accessories for PRXC-250A	Pkg
PRXF-S950	Fuse/Switch Kit consisting of: PRXST100 On/Off Toggle Switch, PRXATM05 5 Amps Mini Fuse & PRXATMF14C In-Line Fuse Holder w/ Cover	Retail Bag
PRXCB-250	Replacement Flash Bulb for PRXC-250A	Clamshell
PRXCL-250A	Replacement Amber Lens for PRXC-250A	Bulk



PRXC-250A

Dual Strobe Light Bar

Dual Quad Flash Strobe Light Bar in alternating sequence. Centre mirrored reflector doubles the effect of the strobe. Small compact design suitable for fitting in a variety of locations.

Part No.	Colour	Flash Pattern	Voltage	Amps	Pkg
PRXC-100A	Amber	Alternating Quad Flash SAE J845 Class 2	12V	1.80	Box

- Lamp Dimension : 16" L x 8-1/2" W x 6" H
- Sturdy ABS Base with Polycarbonate Dome & Lens
- Mounting : 4 mounting screws @ 12-3/4" and 5-1/4" centres

Part No.	Accessories for PRXC-100A	Pkg
PRXF-S950	Fuse/Switch Kit consisting of: PRXST100 On/Off Toggle Switch, PRXATM05 5 Amps Mini Fuse & PRXATMF14C In-Line Fuse Holder w/ Cover	Retail Bag



PRXC-100A

Rotating Beacon Lights

Single Rotating Beacon

Part No.	Colour	Flash Pattern	Voltage	Amps	Bulb	Pkg
PRXC-R880A	Amber	Single Rotating @ 150 fpm SAE J845 Class 1	12V	5	H1	Box
PRXC-R880B	Blue	Single Rotating @ 150 fpm	12V	5	H1	Box

- Lamp Dimension : 7-3/4" H x 8-3/4" Dia
- Aluminium Base with Polycarbonate Lens
- Mounting : 3-1/2" or 7-1/16" centres
- EMC IP65

Part No.	Accessories for PRXC-R880A & PRXC-R880B	Pkg
PRXF-S970	Fuse/Switch Kit consisting of: PRXST100 On/Off Toggle Switch, PRXATM075 7.5 Amps Mini Fuse & PRXATMF14C In-Line Fuse Holder w/ Cover	Retail Bag
PRXF-F680	Mounting Plate & Bracket Set for mounting on pole or mirror arm	Bulk
PRXCL-R880A	Replacement Amber Lens for PRXC-R880A	Bulk
PRXCL-R880B	Replacement Blue Lens for PRXC-R880B	Bulk



PRXC-R880A



PRXC-R880B

Mounting Plate & Bracket Set - for Pole Mount or Mirror Arm Mount



PRXE-F680
Pole Mount



PRXE-F680
Mirror Arm Mount

Part No.	Description	Pkg
PRXE-F680	Mounting Plate & Bracket Set consisting of: 6-1/2" Round Plated Steel Base Mount and Brushed Aluminium Mirror Mounting Bracket with 1/2" centred mounting hole	Bulk

For Use with:

PRXC-330A	PRXC-880BC	PRXE-330A	PRXE-650A
PRXC-330B	PRXC-883AC	PRXE-350A	PRXE-658A
PRXC-550A	PRXC-R880A	PRXE-550A	PRXE-880AC
PRXC-550B	PRXC-R880B	PRXE-553A	PRXE-888AC
PRXC-553A			

Magnet Mount Kit - to convert Lamp to Magnetic Mount



PRXE-FM600

Part No.	Description	Pkg
PRXE-FM600	Magnetic Mount Kit consisting of: 6-1/2" Round Plated Steel Base with Magnet and Rubber Housing Coiled Wire & Cigarette Power Adaptor	Bulk

For Use with:

PRXC-550A	PRXE-350A	PRXE-650A
PRXC-550B	PRXE-550A	PRXE-658A
PRXC-553A	PRXE-553A	

Fuse/Switch Kits



PRXST-100



PRXF-S950

Part No.	Fuse/Switch Kit consisting of:	Pkg
PRXF-S935	PRXST100 On/Off Toggle Switch PRXST108 Momentary On-Off Toggle Switch PRXATS03 3 Amps Standard Fuse PRXATSF14C In-Line Fuse Holder w/ Cover	Retail Bag
PRXF-S950	PRXST100 On/Off Toggle Switch PRXATM05 5 Amps Mini Fuse & PRXATMF14C In-Line Fuse Holder w/ Cover	Retail Bag
PRXF-S955	PRXST100 On/Off Toggle Switch PRXST105 On-Off-Momentary On Toggle Switch PRXATM05 5 Amps Mini Fuse PRXATMF14C In-Line Fuse Holder w/ Cover	Retail Bag
PRXF-S970	PRXST100 On/Off Toggle Switch PRXATM075 7.5 Amps Mini Fuse & PRXATMF14C In-Line Fuse Holder w/ Cover	Retail Bag
PRXF-S975	PRXST100 On/Off Toggle Switch PRXST105 On-Off-Momentary On Toggle Switch PRXATM075 7.5 Amps Mini Fuse PRXATMF14C In-Line Fuse Holder w/ Cover	Retail Bag

SAE Class 1, Class 2 or Class 3? Not sure what to use on your application?

Per SAE specifications:

Class 1 Optical Warning Device is a primary optical warning device for use on authorized emergency vehicles responding to emergency situations. These devices are utilized to capture the attention of motorists and pedestrians and warn of a potentially hazardous activity or situation. Examples of emergency vehicles are police vehicles, fire trucks and ambulances.

Class 2 Optical Warning Device is a primary optical warning device for use on authorized maintenance or service vehicles to warn of traffic hazards such as a lane blockage or slow moving vehicle. Examples of maintenance or service vehicles are tow trucks, snow plow vehicles, Department of Highway road maintenance vehicles and other slow moving vehicles.

Class 3 Optical Warning Device is a primary optical warning device for use on vehicles authorized to display an optical warning device for identification only.

PROVIX.NET
Now I CAN SEE!

LARGE AREA PORTABLE LIGHTING

When the jobsite demands the maximum light output available, PROVIX'S Large Area Lighting is just what is needed. All of these lights offer high-output lighting options and include the durability that you expect from a PROVIX product. From our patented Wobblelight self-righting portable work lights and our Hang-A-Light temporary area work lights, PROVIX has you covered on the ground and overhead.



CALL: 1-888-434-0253 - CONTACT: SALES@PROVIX.NET - VISIT: WWW.PROVIX.NET

PROVIX.NET
Now I CAN SEE!

SMALL AREA PORTABLE LIGHTING

The smaller jobs require portable lighting that is easy to work next to in confined areas, with no hot surfaces but bright enough to get the job done. PROVIX offers several lighting options that meet this criteria while also being energy efficient. Choose from the PROVIX LED Flood Light Series or any of the Defender industrial lighting products for the small jobs. Hang-A-Light offers overhead lighting with those small areas in mind that is cool burning and easy to install. No matter how small or large the area, PROVIX has a light for the job.



CALL: 1-888-434-0253 - CONTACT: SALES@PROVIX.NET - VISIT: WWW.PROVIX.NET

PROVIX.NET
Now I CAN SEE!

BATTERY OPERATED LED LIGHTING

PROVIX Professional Lighting offers many battery operated LED lighting options. All with superior LEDs that produce a bright white light that is easy to work near and have advanced battery technology that allows for maximum run times. When it is critical to the job that the lighting options are battery operated, look no further than the experts, PROVIX Professional Lighting.

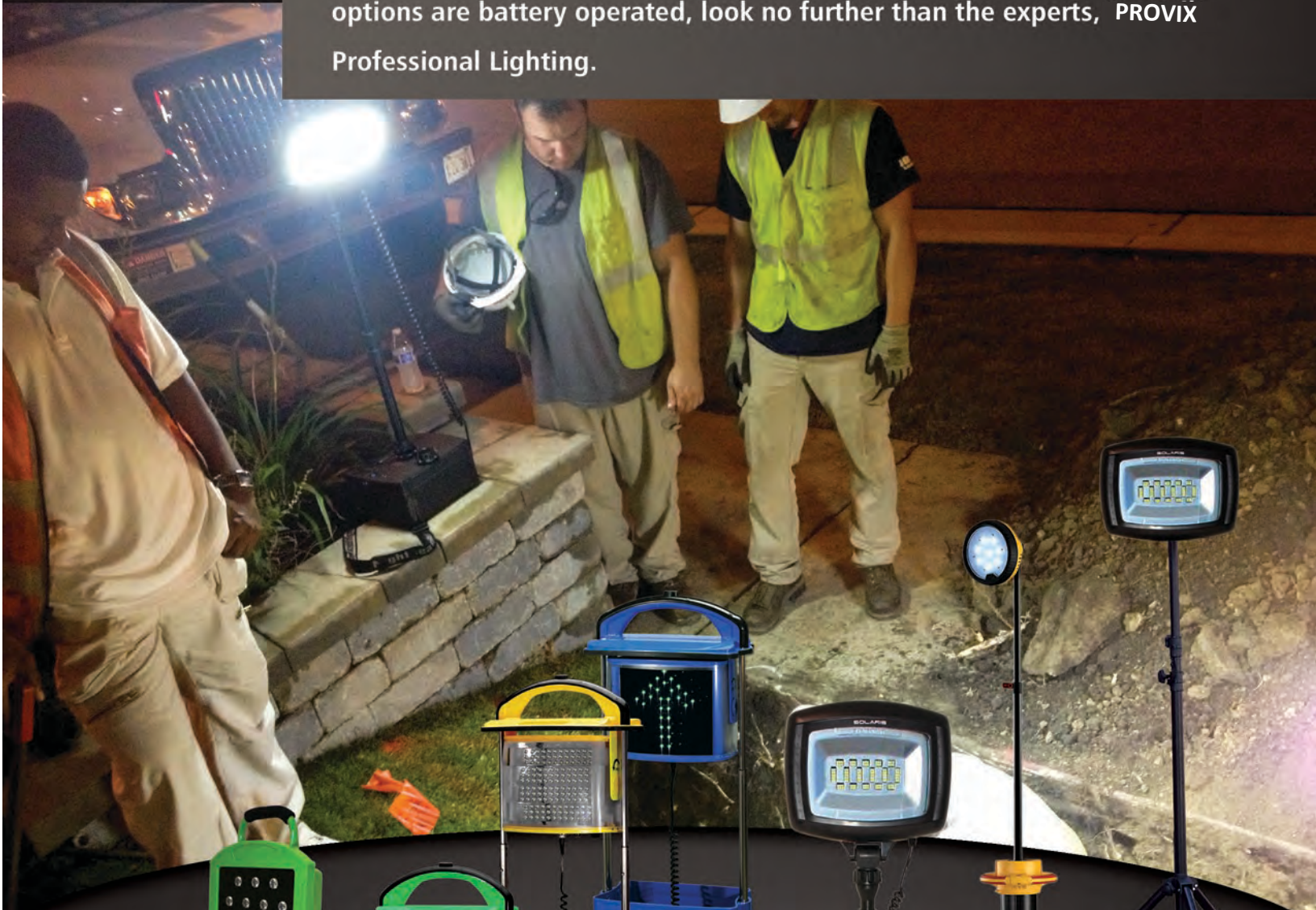

CALL: 1-888-434-0253 - CONTACT: SALES@PROVIX.NET - VIST: WWW.PROVIX.NET

From LED handlamps to high output Torches, PROVIX has a handheld light for your next job! Choose from Defenders rechargeable or replaceable battery operated LED handlamps for those smaller jobs. Or, the PROVIX HID Torches when the job requires military-grade durability and extreme lighting conditions.



PROVIX Professional Lighting realizes that some jobs require a very specialized lighting option and we are committed to bringing that to you. PROVIX' vast network of engineers and manufacturing facilities allows us to customize lighting options for your particular application. Innovation and technology to make your job easier!



LED FLARES: A BETTER ALTERNATIVE TO FUSSE FLARES

ELIMINATE
THE RISK POSED
BY FUSSE FLARES

AN ENVIRONMENTALLY SAFE SOLUTION

An eco-friendly solution that eliminates chemical and smoke residue; safer for the environment and your personnel.

ELIMINATE RISK FIRES

Eliminate dangerous combustible fusee flares that are a risk to vehicles, personnel, and the environment.

IMMEDIATE COST SAVINGS

Self contained led flares last for years. Compared to conventional fusee flares the break even point is after 10 hours of use.

Available in:

Blue, Red, Amber
Blue/Red, White
Green

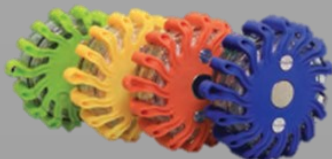

FEATURES

Rechargeable battery
Hard Case with built in charger
Different Colour LEDs
Environmentally friendly



**Premium heavy duty combination headlight with integrated park and signal light.
Sold in pairs. Wire harness included.**

FEATURE	BENEFIT
Superior optics	Crisp clear light output.
Strong & durable	Built for tough conditions.
Combination headlight	Increased road illumination.
Visible park/turn light	Improves road safety
12Vdc or 24Vdc available	Use for light or heavy duty equipment vehicle
Stainless steel bracket	Fast, efficient and accurate mounting.
Pre-wired	Easy to install.

Responder® LP Series

SUPER-LED® MINI LIGHTBARS

Now a low profile mini lightbar that provides all the high performance LED warning and signalling benefits, in a smaller size that fits all your special applications.

Super-LED modules in a rugged aluminum or polycarbonate base are built to take the roughest conditions and long hours you face. They're road tested, vibration and moisture resistant and use a much lower current than other warning lights. Put a Responder LP to work on your utility, security, fleet, construction or public works vehicle.

RDLPPAB shown in both Amber and Blue modes.

DUO



LES-R1LPMA

LES-R1LPVF

LES-R2LPHPR

FEATURES

- Class 1, SAE J845 Certified.
- 100,000 hour rated life.
- Six Super-LED modules.
- Choose from R1LP Series with Conical modules or R2LP Series with Linear-LED® modules.
- DUO™ technology model has different color LEDs in the same module allowing lightbar to flash different colors.
- Built-in electronic flasher with 46 Scan-Lock™ flash patterns including 4 simulated rotating patterns.
- ActionScan™ is the default flash pattern on all mount versions.
- Dual switch cigar plug allows pattern selection in magnetic and magnetic-suction mount models.
- Permanent mount includes 6" pigtail; magnetic and magnetic/suction mounts include 10' straight cord with dual switch cigar plug
- Polycarbonate dome with smooth exterior will not gather dirt and dust.
- 12 VDC.
- R1LP models: 3.0 amp draw (peak), 1.2 amp draw (avg).
- R2LP models: 6.0 amp draw (peak), 2.4 amp draw (avg).

CON3™ MODELS

Polycarbonate Base

- LES-R1LPP*Permanent mount
- LES-R1LPM*Magnetic mount
- LES-R1LPV*Magnetic/Suction mount

Aluminum Base

- LES-R1LPHP*Permanent mount
- LES-R1LPHM*Magnetic mount
- LES-R1LPHV*Magnetic/Suction mount

Polycarbonate Base Dual Color

- LES-R1LPPFPermanent mount, driver side Amber & passenger side White with Clear dome

- LES-R1LPMFMagnetic mount, driver side Amber & passenger side White with Clear dome

- LES-R1LPVFMagnetic/Suction mount, driver side Amber & passenger side White with Clear dome

* Replace symbol with LED color desired, A= Amber, B= Blue and R= Red.

Linear-LED® MODELS

Polycarbonate Base

- LES-R2LPP*Permanent mount
- LES-R2LPM*Magnetic mount
- LES-R2LPV*Magnetic/Suction mount
- LES-RDLPPABDUO, permanent mount, Amber/Blue

Aluminum Base

- LES-R2LPHP*Permanent mount
- LES-R2LPHM*Magnetic mount
- LES-R2LPHV*Magnetic/Suction mount

OPTIONS

- LES-R1\$\$\$00Six CON3 Super-LED modules, insert color, no charge when ordered with R1 split color models

- LES-R2\$\$\$00Six LIN6™ Super-LED modules, insert color, no charge when ordered with R2 split color models

Replace " * " with an "S" and use Lighting Package R1\$\$\$00 for R1 models and R2\$\$\$00 for R2 models. Replace Symbol "\$" with the number of color LED lightheads required (maximum of six). Order of color is Red, Blue and Amber.



Available in Red, Amber, and Blue

WHELEN®



DETECT · ALERT · REACT with PROVIX!

PROVIX is a leading supplier of Proximity Detection and Collision Avoidance systems that increase safety, prevent accidents and increase productivity.

PROVIX Proximity detection systems and Equipment Blind Spot Cameras serve to enhance safety by increasing operators' situational awareness of surrounding vehicles and personnel.

PROVIX supplies Backsense object detection that utilises Radar technology to alert vehicle and equipment operators of the presence of any object within the desired detection zone of a vehicle.

PROVIX supplies Self-adjusting, broadband/ white noise reversing alarms that are safer for workers. These intelligent back up alarms reduce noise complaints and eliminate worker acclimatization associated with conventional tonal alarms as they are only heard within the danger area of the reversing vehicle.

PROVIX Safety systems keep workers safe and reduce equipment damage costs.

Contact your PROVIX tech rep to discuss how to best protect your personnel and equipment.

Proactive Combination Safety System

DETECT, ALERT, REACT *Before accidents can occur*

- ◆ Provides driver with audible and visual in-cab warning
- ◆ Integrates powerful object detection radar with safety cameras to notify drivers of surrounding objects
- ◆ Robust Radar detects objects even when the camera view is hindered
- ◆ Broadband alarm notifies people around vehicle
- ◆ Enhances Safety all around the vehicle!



1) Equipment Cameras

2) Proximity Detection

3) Broadband White noise-
Back-up Alarm

Provox integrates the consistency of our Radar Sensors with the quality of our cameras to provide drivers with a comprehensive object detection solution that meets the rugged conditions common in the heavy equipment industry.

1



Equipment Cameras

Visual Warning

1 for reversing

- add up to 3 more

2



Proximity Detection

Detect and Alert with

Audible Warning

-1 Rear Sensor, 2 in front

3



Broadband Back-up Alarm

Alert people around vehicle



Eliminate Noise Complaints NOW!
Increase Worker Safety
Keep Your Neighbors Happy!



BROADBAND WHITE SOUND BACK-UP ALARMS

INTRODUCING THE SMART, SELF-ADJUSTING BBS-TEK® BACK-UP ALARMS

WITH VOLUME RANGES FROM 77-97DB(A) AND 87-107DB(A)



MAKING THEM IDEAL FOR TRUCKS, BUSES, COACHES, FORKLIFTS, AIRPORT VEHICLES,

CONSTRUCTION & MINING MACHINERY, AS WELL AS WORKING IN AREAS WHERE THE AMBIENT NOISE LEVEL MAY VARY SIGNIFICANTLY.



77-97db



87-107db

PROVIDES GREATER SAFETY & LESS NOISE NUISANCE THAN ANY OTHER ALARM!

KEY BENEFITS:

- 'Smart' self-adjusting sound level
- Ambient noise is monitored once every second
- Automatically adjusts the alarm volume 5-10dB above the sampled noise level
- Sound is instantly locatable so you can tell which vehicle is reversing
- Focuses warning sound in the danger zone behind the vehicle, so it doesn't annoy site neighbors or other people
- Unlike conventional alarms, the 'shh... shh...' sound of broadband sound (white sound) is easy on the ear and dissipates fast outside the danger area
- Tough, Durable, Waterproof (IP68)
- Conforms to SAE J994 environmental standards
- Solid state, spark-free electronics
- Epoxy sealed for protection against vibration, dust and moisture

*This is particularly important for vehicles maneuvering in close proximity to each

other or going from a noisy environment, such as a factory floor, to a quieter external

location, such as a work yard, ensuring the warning is always heard.



<u>SPECIFICATION:</u>	<u>97:</u>	<u>107:</u>
POWER INPUT	12-24Vdc	12-24Vdc
POWER CONSUMPTION	0.5	1.0
SOUND LEVEL (DB(A)@1M)	77-97	87-107
SOUNDER UNIT	Speaker	Speaker
FREQUENCY	Multi	Multi
DIMENSIONS (IN.)	5 x 2.5 x 3.6	7 x 3.7 x 3.1

CALL TOLL FREE: 1-888-434-0253 — CONTACT: SALES@PROVIX.NET — VISIT: WWW.PROVIX.NET

Provix Broadband Alarms– The Benefits

SAFETY – Much Greater Safety

- **Their sound is locatable**
The location of a broadband sound source is instantly and unambiguously recognisable and reveals immediately which vehicle or machine is backing-up. Narrowband sound is liable to give false directional clues due to reflection off surfaces such as buildings, quarry faces etc. sometimes with fatal results
- **Sound is localised within hazard area**
Familiarity with unneeded warning alarms heard *outside* the hazard area breeds general contempt for them – very dangerous when real need is.
- **Audible through Ear Defenders**
The lower frequencies of their broad frequency spectrum penetrate ear defenders more readily than the higher frequencies of narrowband alarms
- **End to intentional disconnects**
Operators and site workers, driven mad by old narrowband alarms, are very happy to work with broadband and appreciate its safety value

ENVIRONMENT – End To Noise Complaints

- **Rapid Sound Dissipation**
Broadband sound dissipates much faster than narrowband. This results in its warning sound being confined to the hazard area.
- **Less Irritating**
Psychoacoustically, broadband sound is tolerable whereas pulsed narrowband sound disturbs and irritate workers and householders far from the hazard area.
- **Less decibels**
Broadband sound is *equally audible at lower Sound Pressure Levels* than narrowband.

HEALTH – Reduce Hearing Damage & “Startle”

- **Reduced risk of Hearing Damage**
Lower sound-pressure levels spread across a broad frequency-band diminish the hearing-damage hazard of high narrowband frequencies (the stiletto heel effect)
- **Heart risk due to “startle”**
Sudden burst of loud narrowband sound nearby can cause severe heart stress due to the “startle” factor

NOISE - The 21ST Century Pollutant

”Calling noise a nuisance is like calling smog an inconvenience”,

Dr William H. Stewart, former Surgeon General of USA

“Noise is any loud, discordant or disagreeable sound or sounds”

Webster’s New World Dictionary

Broadband back-up alarms are “noiseless” – their sound is neither loud, discordant nor disagreeable. Traditional, old narrowband alarms are intrinsically unsafe, noisy, irritating, disagreeable, injurious to health, cause stress and are frequently sabotaged. They are now obsolete.

PROVIX FLEET MANAGEMENT GPS

VEHICLE TRACKING SOLUTIONS MADE SIMPLE, RELIABLE, AND AFFORDABLE



HARDWIRED UNIT

- HARDWIRED – CANNOT BE EASILY REMOVED BY VEHICLE OPERATOR
- NOTIFICATION THAT POWER IS LOST IF UNPLUGGED BY OPERATOR
- INTERNAL 200 MAH BACKUP BATTERY
- ACCURATE LOCATION WITHIN 2 METERS

USER FRIENDLY WEB BASED PROGRAM

PROVIX.NET
Now I CAN SEE!

Welcome, John Stead
Log Out

Overview History Notifications Settings FAQ Support

All Readings Idles Stops Trips Speed Alerts Zone Alerts Device Battery Alerts

For: Provix1 From: 2015-11-05 00:00 To: 2015-11-16 23:59 Go

Location	Speed	Event Type	When (EST)
455 Government Rd W, Cha...	0	Engine On	15 Nov 2015 07:13:57 PM
455 Government Rd W, Cha...	0	Engine Off	15 Nov 2015 07:10:48 PM
ON-66, Chaput Hughes ON	89		15 Nov 2015 07:08:51 PM
ON-112, Kirkland Lake ON	84		15 Nov 2015 07:06:51 PM
71 ON-112, Chaput Hughes ...	100		15 Nov 2015 07:04:51 PM
71 ON-112, Chaput Hughes ...	97		15 Nov 2015 07:02:51 PM
ON-112, ON	100		15 Nov 2015 07:00:51 PM
ON-112, ON	101		15 Nov 2015 06:58:51 PM
ON-112, Tarzwell ON	98		15 Nov 2015 06:56:51 PM
6120 ON-11, ON	58		15 Nov 2015 06:54:51 PM
ON-11, Tarzwell ON	104		15 Nov 2015 06:52:51 PM
336352 ON-11, Englehart ON	106		15 Nov 2015 06:50:51 PM
ON-11, Englehart ON	108		15 Nov 2015 06:48:51 PM
ON-11, Englehart ON	107		15 Nov 2015 06:46:51 PM
ON-11, Englehart ON	108		15 Nov 2015 06:44:51 PM
334416 ON-11, Englehart ON	85		15 Nov 2015 06:42:51 PM
330 Trans-Canada Hwy, En...	110		15 Nov 2015 06:40:52 PM
330 Trans-Canada Hwy, En...	108		15 Nov 2015 06:38:52 PM
ON-11, Earlton ON	106		15 Nov 2015 06:36:52 PM
Trans-Canada Hwy, Earlton...	107		15 Nov 2015 06:34:52 PM
ON-11, Thomloe ON	107		15 Nov 2015 06:32:52 PM

Previous 1 2 3 ... 33 Next

OBD PLUG-IN UNIT

- NOTIFICATION THAT POWER IS LOST IF UNPLUGGED BY OPERATOR
- OBD PLUG IN THAT CAN BE REMOVED BY OPERATOR
- INTERNAL 200 MAH BACKUP BATTERY
- ACCURATE LOCATION WITHIN 2 METERS



PROVIX.NET
Now I CAN SEE!

CALL TOLL FREE: 1-888-434-0253

CONTACT: SALES@PROVIX.NET

VISIT: WWW.PROVIX.NET

ISO 9001: 2015 Certified